

ADVANCED COLOR LOGIC®



Models 254-200 & 254-201 Calibration Procedure P/N 031-0186



CAUTION

Performing the following Tests and Calibration requires the operator to be near HIGH VOLTAGES and HIGH CURRENTS. Operator must be familiar with working in this environment and exercise caution during this procedure to avoid any shock hazards.

TABLE OF CONTENTS

- 1.0 EQUIPMENT NEEDED 3
 - 1.1 LOAD BANK 3
 - 1.2 LIVE ARC 3
- 2.0 EQUIPMENT SETUP 5
 - 2.1 ACL SETUP 5
 - 2.2 CALIBRATION WELD BOX LOAD 5
- 3.0 HARDWARE CALIBRATION 7
 - 3.1 SERVO BOARD SETUP 7
 - 3.1.1 VOLTAGE OFFSET ADJUSTMENT 8
 - 3.1.2 CURRENT OFFSET ADJUSTMENT 9
 - 3.2 CALIBRATION PREPARATION 9
- 4.0 SOFTWARE CALIBRATION 13
 - 4.1 MOTOR CALIBRATION 13
 - 4.2 VOLTAGE CALIBRATION 13
 - 4.3 CURRENT CALIBRATION 14
- 5.0 FINAL CALIBRATION, VERIFICATION, AND DOCUMENTATION 16
 - 5.1 CALIBRATION VERIFICATION SETUP 16
 - 5.2 WELDHEAD MOTOR SERVO CALIBRATION VERIFICATION 16
 - 5.3 ARC VOLTAGE CALIBRATION VERIFICATION 17
 - 5.4 CURRENT CALIBRATION VERIFICATION 17
- Appendix A 19
- Appendix B 20
- Appendix C 23

1.0 EQUIPMENT NEEDED

In addition to the ACL, other pieces of Test/Calibration tools and equipment are required. Depending on the type of calibration to be performed, LOAD BANK or LIVE ARC, different equipment and tools may be required. See images immediately following for reference.

1.1 LOAD BANK

- 44 pin Test Extender Card
- Small Plastic Flathead Screwdriver
- Small Phillips Screwdriver
- 1/4" Hex Wrench
- 3/16" Hex Wrench
- Glyptol Insulating Varnish
- Certified Digital Multi-Meter (Fluke 8060A or Equivalent) and Test Leads
- 30V / 1A or higher DC External Power Supply and Test Leads

1.2 LIVE ARC

- Calibration Kit (P/N 005-0251)
- Orbital Weldhead
- Water Recirculator
- Feeler Gauge
- Wire Brush



External DC Power Supply



Digital Mutli Meter - Certified



Glyptol Varnish



Calibration kit (P/N 005-0251)



1/4" Hex Driver & Small Plastic Screwdriver



44 Pin Extender Card



Hook and Feeler Gauge

NOTES:

2.0 EQUIPMENT SETUP

2.1 ACL SETUP

It is recommended to use 208 to 240 VAC input power for the calibration procedure. Prior to starting the calibration, the ACL should be in TEACH mode. **All commands during the calibration procedure must be executed using the Hand Held Control (HHC).**



2.2 CALIBRATION WELD BOX LOAD

Adjust torch in load box for proper weld gap (**0.065~0.093 in**) with feeler gauge and ensure tungsten and plate surface are clean, use wire brush if necessary. Also make sure the tungsten diameter is **3/32" OD**.

CAUTION

Before beginning final calibration, record test equipment data on the Certificate of Calibration and **VERIFY THAT ALL TEST EQUIPMENT USED HAS A CURRENT UNBROKEN CALIBRATION SEAL**. Use of uncalibrated test equipment will invalidate the calibration you are about to perform.

NOTES:

3.0 HARDWARE CALIBRATION

Current and voltage offset adjustment using CAL 200 procedure is a quick way of checking the low and high end of the current and voltage.

NOTE
Before beginning calibration, turn the unit on and verify that it is operating normally and that the main menu is displayed with no problems. Then turn the unit off.

3.1 SERVO BOARD SETUP

Make sure the unit is powered down. Use the 1/4 inch Hex Wrench to remove the Low Window shield on the back of the ACL Power Supply.



Removing Low Window Shield

Remove the Servo Board (which is the lower of the two boards). The easiest way is to use the hook, or something similar, to grab the white corner spacers of the board and ease it out. Once the Board is out, insert the Test Extender Card in its place, and then reconnect the Servo Board to the other end of the Test Extender Card.



Remove Board with Hook



Insert Extender Card



Connect Servo Board to card

NOTE

Place an anti-static material beneath the Servo Board (ie. Anti-static bag,) so that it does not rest directly on the ACL's fan. Also, the black shield can be removed from the Servo Board for easier access to components, but must be replaced before the board is placed back into the machine. It is removed in these pictures to better demonstrate the location of certain components. We recommend that you remove it, but the adjustments can be made without the cover's removal. To remove the cover, use the Small Phillips Screwdriver and the 3/16-inch Hex Wrench.

3.1.1 VOLTAGE OFFSET ADJUSTMENT

Place the **Meter GND(-)** lead on **TP8** (which is located on the left side near the front, directly behind the white corner spacer) and the **Meter POS(+)** lead on **TP9** (which is located slightly back from the front on the right side of the board.)

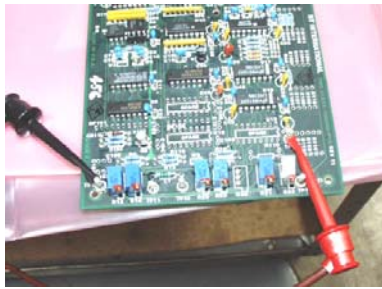

Test Points 8 and 9

Turn the ACL unit on. Verify that the voltage across the test points is \emptyset (+/- 2mV). If not, use the screwdriver to adjust the **R42** trim pot (located near the back of the Servo Board, second from the right) until the reading is \emptyset (+/- 2mV).

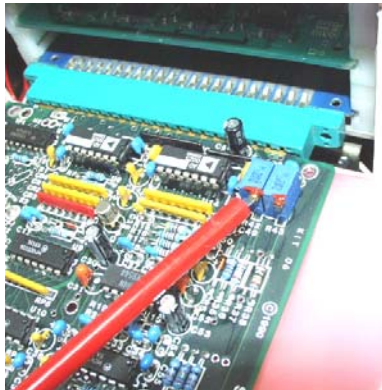

Adjusting R42

3.1.2 CURRENT OFFSET ADJUSTMENT

You will need to use the **CAL200** disk to perform this part of the Calibration Preparation. If you do not have the disk, go to mkproducts.com and download onto a floppy disk.

NOTE

Work as quickly as possible whenever an Arc is established, especially at high Amperage. This is necessary because the ACL does not pulse when calibrating and therefore heats up more quickly than usual. The power supply will shut off if it gets too hot. If this happens, let the machine cool down and then try again.

3.2 CALIBRATION PREPARATION

First, turn on the ACL, press ENTER until main menu appears. Second, insert CAL200 floppy disk into disk drive then press the 'F' key on the keyboard or hand held control to copy procedure from disk. In the next screen (with CAL200 on it), use blue arrow keys to highlight the CAL200 Procedure, then press ENTER. The ACL will ask you if you want to "SAVE TO STATIC RAM" (at the bottom of screen). Press NO. The content of the screen does not change and, again, use blue arrow and highlight the CAL200. Press "MAIN MENU" key. Finally, the main menu appears and its first line shows "*Weld with Procedure CAL200*". **Remove disk from disk drive.**

WARNING

Do not Save the Procedure to the ACL memory. It is to be used for Calibration only, and afterwards to be removed from the ACL. Failure to comply could result in serious injury.

The current calibration requires that the ACL be generating an arc. Configure the ACL with the Calibration Torch and Water Recirculator (refer to **Appendix A**). Verify that the Water Recirculator is on before continuing.

Move the **Meter GND(-)** lead to **TP10** and the **Meter POS(+)** lead to **TP11** or you can simply connect the leads to the Current Shunt on the Calibration Kit Shunt Box.



Test Points 10 and 11

Turn on the Gas by pressing **NEXT LEVEL/GAS**. Use the flow meter on the front of the ACL, and set the flow between 30 and 40 cfh. Place unit into Weld Mode by using the green button on the front of the ACL.

Turn DMM off and press Key 1, then weld procedure appears. Start the CAL200 Weld Procedure by hitting the START/STOP key. At the end of the pre-purge cycle, "touch start" the torch. Once arc is established, the DMM can be turned back on.

The difference's using water and air cooled calibration kits.

With an AIR COOLED weld box (weld box enclosed without fan or window) temperature goes up too fast encouraging DMM readings to become unstable. If so, the pot adjustment becomes most difficult to obtain the specified limit of 1% tolerance (.05mV and .5mV for 20A and 180A, respectively). The more time you have to wait for the reading to stay stable, the higher the torch temperature and incidents for torch damage.

With a WATER COOLED weld box, the reading is more stable. You are able to repeat several times between ranges of 20A and 180A. By that, you can adjust current offset to the minimum of tolerance.

Immediately press **NEXT LEVEL** once the Arc has been established because level #2 is for 180 amps. This will put the Unit into level 3 of the weld procedure, where the ACL will output 20 Amps. Divide this current by 4 to obtain the "correct value" in mV (5mV). Measure the voltage across the Current Shunt (on the box or TP10 & TP11). If the two values do not agree, adjust **R43** trim pot (located near the back of the Servo Board on the right edge) until the voltage across the shunt equals the calculated "correct" value

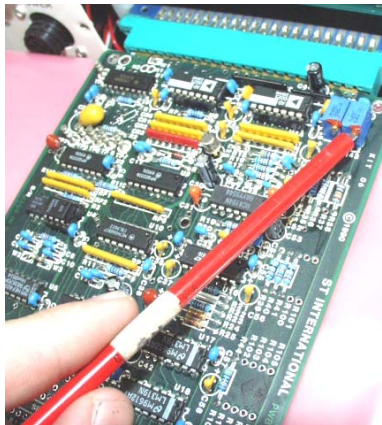

Adjusting R43

Press **NEXT LEVEL** and the output will climb to approximately 180 Amps. Divide this current by 4 to obtain the approximate value (45 mV). If the current bar graph on the monitor or on handheld display does not show 180 Amps, adjust **R32** trim pot (located at the front of the Servo Board on the right) until it does

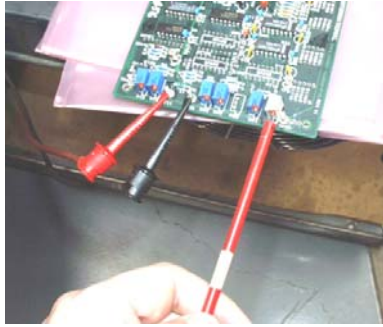

Adjusting R32

Press **NEXT LEVEL** and verify that the shunt reading is 5.0 mV +/- .3 mV and the current bar graph reading is 20 Amps +/- 1%.

Press **NEXT LEVEL** and verify that the shunt reading is approximately 45.0 mV and the current bar graph reading is 180 Amps +/- 1% or current on handheld is 180 Amps +/- 1%. Repeat steps 3.3.6 and 3.3.7, if necessary.

Press **START/STOP** on the H.H.C. Press **ESCAPE** to take you to the main menu.

Turn the ACL unit off. Remove the Servo Board and use glyptol to seal potentiometer settings on trim pots **R42**, **R43**, and **R32**. If you removed the Servo Board's black cover, be sure to replace it.

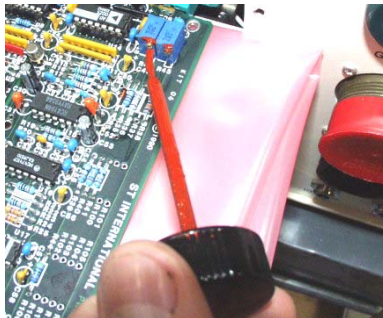

Sealing R32, 42 & 43

Remove the Test Extender Card and Re-insert the Servo Board. Use hex wrench to replace Servo Board shield.

NOTES:

4.0 SOFTWARE CALIBRATION

NOTE: It is recommended that you turn the gas off at this point, because it will not be needed in this section of Calibration.

4.1 MOTOR CALIBRATION

NOTE: PERFORM PROCEDURE IN TEST MODE and Turn Gas Off.

From the Main Menu press **9** to return to the **ANACAL** procedure.

The Motor Calibration will run through procedure levels at: 0.5, 1, 2, 3, 4, 5, 6, 7, 8, 9, & 10 rpm. (These are called DEMAND VALUE and are shown at bottom line for motor RPM, in Level # paragraph on right side of screen.)

NOTE: RPM is calibrated by using the two most recent rotations. Therefore, to obtain an accurate reading and calibration, the rotor must complete two rotations after each adjustment on the H.H.C. This will be time consuming on the lower speeds but is essential for an accurate calibration.

Press **START/STOP**. Then use the **RIGHT ARROW** (for an increase) or **LEFT ARROW** (for a decrease) to adjust the "ACTUAL RPM" (located to the right and below the Motor Bar Graph) until the "ACTUAL RPM" is equal to the correct RPM DEMAND VALUE (located on line RPM motor in Level # paragraph on right side of screen). After the "Actual RPM" equal to "RPM Demand", use the % Motor Scale up or % Scale Down keys to adjust the "display RPM" to the right of motor bar until the "Display RPM" equals to the correct RPM DEMAND VALUE.

NOTE: At least one-second before a 300 second limit for each level expires (look at time countdown on the screen), press ENTER key to save the calibrated data. ANA_CAL will automatically jump to next level to proceed with the calibration.

Press **START/STOP** when finished with all levels. Press **ESCAPE** to return to the Main Menu.

4.2 VOLTAGE CALIBRATION

NOTE: PERFORM PROCEDURE IN TEST MODE and Turn Gas Off.

Turn the ACL back on. In the Main Menu press menu selection **9** to select the **ANA_CAL** weld procedure.

Connect a DC Power Supply to the Voltage Input of the Calibration Kit Shunt Box. Press **START/STOP**. Adjust input to 2VDC from the DC Power Supply.

Adjust the "ARC VOLTAGE" (displayed to the right of the Voltage Bar Graph on the monitor) by pressing **PAGE UP** or **PAGE DOWN** until it is the same as

the supplied input voltage. Press ENTER key to save the voltage calibration setting.

Repeat Step 4.2.3 but input other voltages and perform the same procedure. Increases inputs: 4V, 6V, 8V, 10V, 12V, 14V, 16V, 18V and 20V.

Press **ESCAPE** to exit to the Main Menu.

NOTE: This will save the Voltage Calibration settings.

4.3 CURRENT CALIBRATION

CAUTION:

PERFORM PROCEDURE IN WELD MODE and TURN GAS ON. Disconnect DC Power Supply from power source to protect from the Arc start power surge. Also turn DMM on only after the Arc has been established.

Return to the **ANA_CAL** procedure by pressing **9** from the Main menu.

Attach DMM leads to the Calibration Kit Current Shunt Box. Do not turn the meter on until after the arc is established.

NOTE: Work as quickly as possible on whenever an Arc is established, especially at high Amperage. This is necessary because the ACL does not pulse when calibrating and therefore heats up more quickly than usual. The power supply will shut off if it gets too hot. If this happens, let the machine cool down and then try again.

The Current Calibration will run through the following Amperages: 10, 20, 40, 60, 80, 100, 120, 140, 160, 180, 200. This can be seen on the ACL Calibration Data Sheet (Attached). The corresponding voltages can be found by dividing the number of Amps by 4. (i.e. 50mV = 200Amps)

Press START/STOP on the H.H.C. and stepping through all procedure levels adjust the "ACTUAL OUTPUT CURRENT" (in mV from DMM) by pressing UP ARROW or DOWN ARROW until the voltage across the Calibration Kit current shunt reads the correct demand value. At the same time adjust the "CURRENT DISPLAY" (To the right and of the Current Bar Graph) by pressing **%CURRENT SCALE UP** or **%CURRENT SCALE DOWN** until the DISPLAY CURRENT reads the correct demand value.

When you have calibrated the current for one level, press ENTER key to save data and quickly move to the next by pressing **NEXT LEVEL**.

Press **START/STOP** when finished with all levels. Press **ESCAPE** to return to the Main Menu.

NOTES:

5.0 FINAL CALIBRATION, VERIFICATION, AND DOCUMENTATION

5.1 CALIBRATION VERIFICATION SETUP

Upon successful completion of burn-in the unit will be verified using procedure CALVRFY (Calibration Verify). There should NOT be a need to recalibrate or adjust any of the ACL inputs or outputs with the H.H.C. or Keyboard. All data will be recorded neatly and completely on the ACL Calibration Data sheet (attached to this document)

Verify that the Weld Box is set up properly. Adjust torch in load box for proper weld gap (**.065~.093-inch**) with feeler gauge and ensure tungsten and plate surface are clean, use wire brush if necessary. Also make sure the tungsten is **3/32 in** (OD Size).

CAUTION:

Before Beginning final calibration, record the test equipment data on the Certificate of Calibration and VERIFY THAT ALL TEST EQUIPMENT USED HAS A CURRENT UNBROKEN CALIBRATION SEAL. Use of uncalibrated test equipment will invalidate the calibration you are about to perform.

5.2 WELDHEAD MOTOR SERVO CALIBRATION VERIFICATION

NOTE: PERFORM PROCEDURE IN TEST MODE and Turn Gas Off. Also, motor speed is calibrated by using the two most recent rotations. Therefore, to obtain an accurate reading and calibration, the rotor must complete two rotations at each level. This will be time consuming on the lower speeds, but is essential for an accurate calibration.

Use CALVRFY procedure to verify motor speed in RPMs.

Press **NEXT LEVEL** to step through the speeds indicated on the data sheet.

Record the ACTUAL RPM of the weld head motor (displayed to the right and below the Motor Speed Bar Graph) on the monitor at each of the speeds.

Also at each of the speeds, record the DISPLAYED RPM (displayed to the right of the Motor Speed bar graph.)

Verify that each of the recorded values equal: = the Demand Speed (+/- .05 RPM) or (Demand Speed +/- 1%) whichever is greater.

Press **START/STOP** when finished.

Run the Weldhead Calibration Menu selection for the Weldhead and printout the Calibration results and attach to test log.

5.3 ARC VOLTAGE CALIBRATION VERIFICATION

NOTE: PERFORM PROCEDURE IN TEST MODE and Turn Gas Off.

Connect the Power Supply to the Input Voltage of the Calibration Kit shunt box. Press **START/STOP**. Input the Voltage demand levels that are on the data sheet.

Record the DISPLAYED VOLTAGE (located to the right of the Voltage Bar Graph on the monitor) onto the Data Sheet.

Verify that each of the recorded values equal: = the Input Voltage +/- 1% VDC.

Press **START/STOP** when finished. Then press **ESCAPE** to return to the Main Menu.

5.4 CURRENT CALIBRATION VERIFICATION

NOTE: PERFORM PROCEDURE IN WELD MODE and TURN GAS ON. Disconnect DC Power Supply from power source to protect from the Arc start power surge. Also turn DMM on only after the Arc has been established.

Connect **DMM** leads to the current shunt of the Calibration Kit shunt box. **Do not turn the meter on until an Arc has been established.**

Press **START/STOP** to establish an arc. Record the ACTUAL CURRENT in mV via the current shunt, and the ACTUAL OUTPUT in Amps (displayed on the screen to the right and below the Current Bar Graph.) Also record the DISPLAYED CURRENT to the right of the Current Bar Graph on the monitor. Step through all the required demand levels on the data sheet by pressing **NEXT LEVEL** and record the values for each.

Verify that each of the recorded values equal: = the Demand Current (+/- 1% Amp)

Press **START/STOP** when you verified all levels. Then press **ESCAPE** to return to the Main Menu.

ACL CALIBRATION DATA

Power Supply S/N _____ Weldhead S/N _____ Software Version _____

CURRENT CALIBRATION DATA

<u>DEMAND</u> (A)	<u>SHUNT</u> (mV)	<u>ACTUAL</u> <u>OUTPUT</u> (A)	<u>DISPLAY</u> <u>OUTPUT</u> (A)	<u>DEMAND</u> (A)	<u>SHUNT</u> (mV)	<u>ACTUAL</u> <u>OUTPUT</u> (A)	<u>DISPLAY</u> <u>OUTPUT</u> (A)
				100	_____	_____	_____
10	_____	_____	_____	120	_____	_____	_____
20	_____	_____	_____	140	_____	_____	_____
40	_____	_____	_____	160	_____	_____	_____
60	_____	_____	_____	180	_____	_____	_____
80	_____	_____	_____	200	_____	_____	_____

ARC VOLTAGE CALIBRATION DATA

INPUT (V)	2	4	6	8	10	12	14	16	18	20
DISPLAY (V)	_____	_____	_____	_____	_____	_____	_____	_____	_____	_____

MOTOR SERVO CALIBRATION DATA

<u>DEMAND</u> (RPM)	<u>ACTUAL</u> (RPM)	<u>DISPLAYED</u> (RPM)	<u>DEMAND</u> (RPM)	<u>ACTUAL</u> (RPM)	<u>DISPLAYED</u> (RPM)
0.5	_____	_____	6	_____	_____
1	_____	_____	7	_____	_____
2	_____	_____	8	_____	_____
3	_____	_____	9	_____	_____
4	_____	_____	10	_____	_____
5	_____	_____			

TECHNICIAN _____ DATE _____

Appendix A

Diagram System Calibration Interface

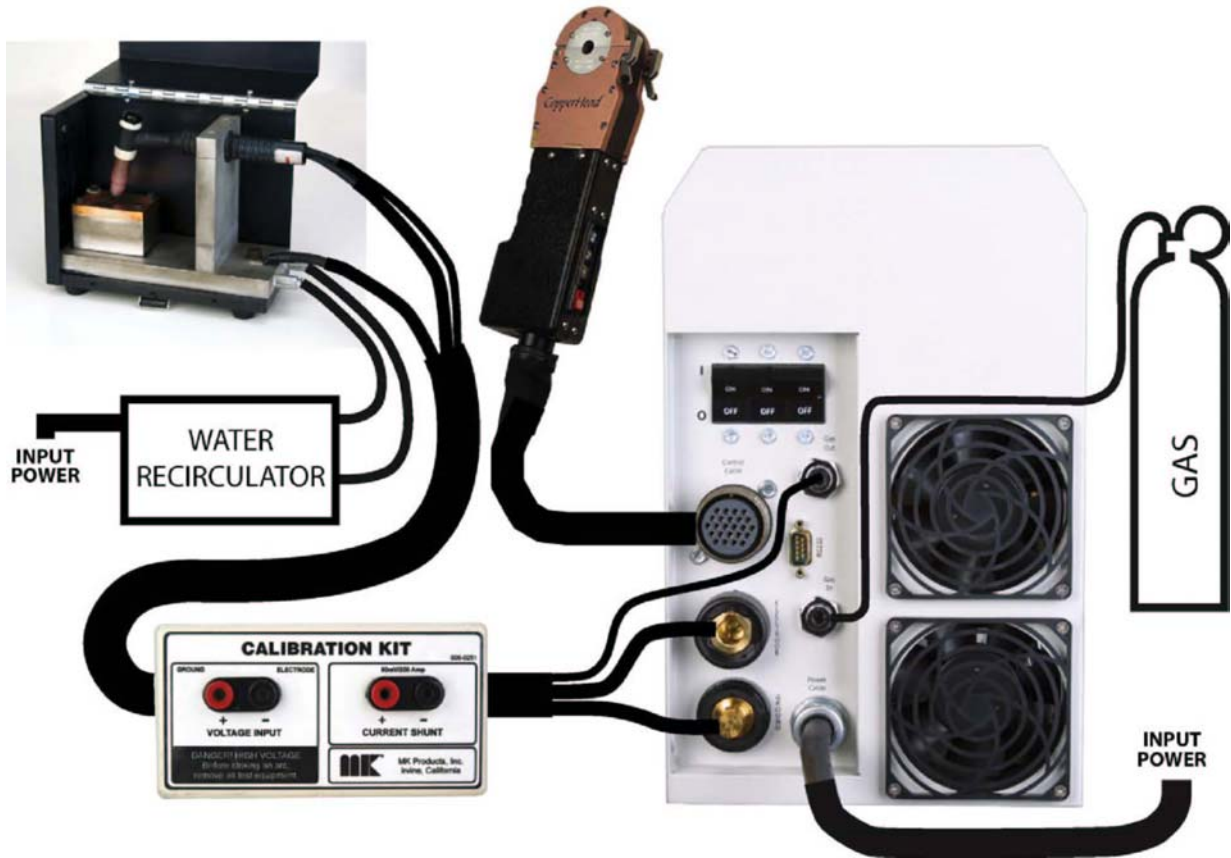

Appendix B

1. ACL CALIBRATION LOAD BANK.

Resistor: 0.6 Ohm @ 1000 Watt & QTY: 6

OHMITE Manufacture P/N PFE5KR600

Circuit breaker: Single pole @ 50 Amp & QTY: 6

E-T-A Circuit breaker P/N 8340-F110-P1M1-A0H0-50A

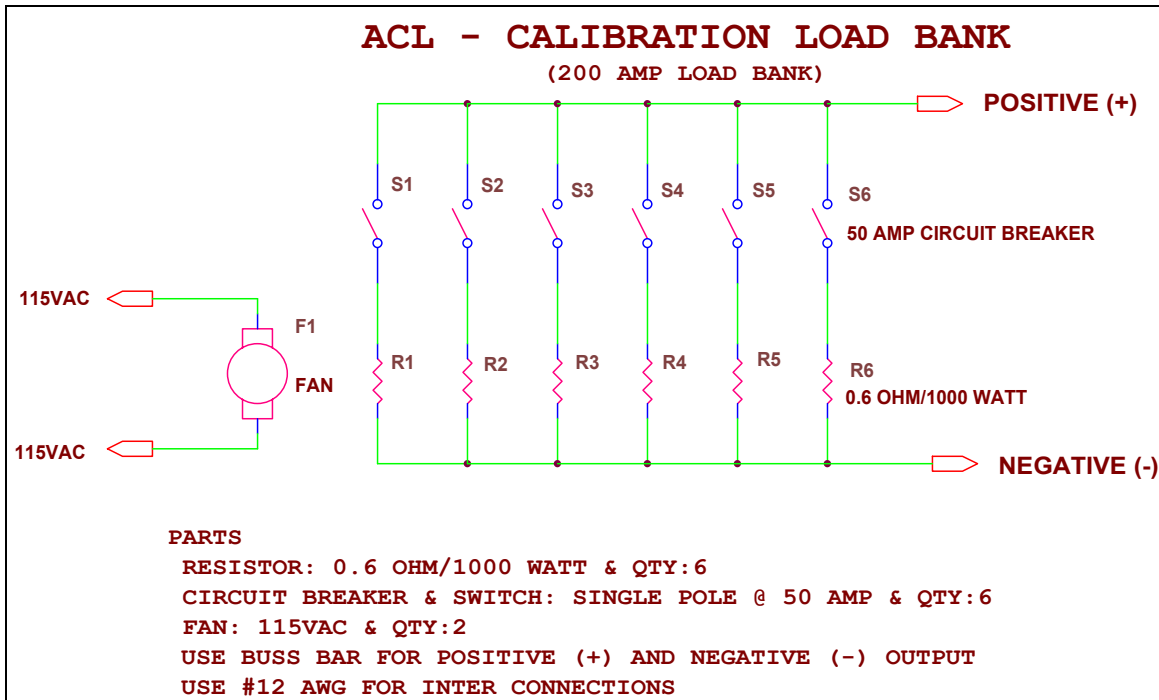

Appendix B cont.

CURRENT CALIBRATION DATA FOR RESISTOR LOAD

<u>TURN ON SWITCH</u>	<u>DEMAND (A)</u>	<u>SHUNT (mV)</u>	<u>ACTUAL OUTPUT (A)</u>	<u>DISPLAY OUTPUT (A)</u>
S1	10	_____	_____	_____
S1	20	_____	_____	_____
S1, S2	40	_____	_____	_____
S1, S2	60	_____	_____	_____
S1, S2, S3	80	_____	_____	_____
S1, S2, S3	100	_____	_____	_____
S1, S2, S3, S4	120	_____	_____	_____
S1, S2, S3, S4	140	_____	_____	_____
S1, S2, S3, S4, S5	160	_____	_____	_____
S1, S2, S3, S4, S5	180	_____	_____	_____
S1, S2, S3, S4, S5, S6	200	_____	_____	_____

NOTE:

Shunt is measured at TP10 and TP11 on Servo board (Section 1.3.3 - Picture)

Appendix B cont.

2. ACL BLOCK DIAGRAM OF HARDWARE CALIBRATION PROCESS

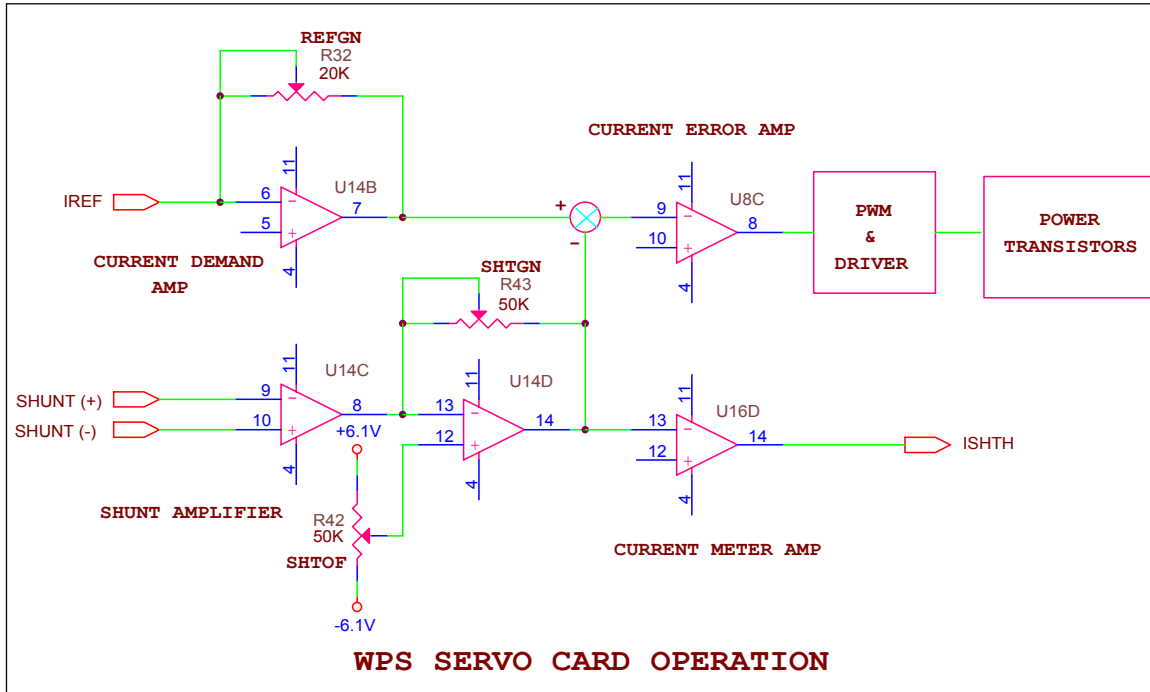

1. Theory of Operation

U14B amplifies current demand from Digital controller. Weld current is measured by the shunt and amplified by U14C, U14D. These two signals are applied to Current error amplifier to regulate the weld current by using Pulse Width Modulation technique. As the pulse width output to Power Transistors increases the weld current increases and as the width decreases the weld current decreases. U16D sends actual welding current back to Digital controller for Monitor & Hand held displays or for current calibration etc. R42, R43 and R32 potentiometers are used to adjust Shunt offset, Shunt gain and Demand gain respectively.

2. Potentiometer Calibrations

- Adjust R42, Shunt offset, for offset voltage to +/- 2mVDC.
- Apply 20 Amp welding current and adjust R43, Shunt gain, such that voltage across the Shunt is 5mVdc +/- 1%.
- Apply 180 Amp welding current and adjust R32, Demand gain, such that the hand held displays 180 Amp +/- 1%.

Appendix C

Software Calibration Details

The hardware calibration assumes that the hardware is linear in error and it calibrates only the amount and the slope of the error. When the hardware is not linear, and in most cases it is not, the software calibration tries to fine adjust the values to be even closer to the actual values.

The software divides the full range of the values (current, voltage and motor speed) into 21 smaller segments and the user calibrates these segments one at the time. Then, these calibration values are used anytime the actual value falls in a corresponding segment area. In most cases, the values will not be at the exact calibration points, so the linear interpolation is used for all of the values in between calibration points.

For example, for current, the segments are:

0-10-20-30-40-50-60-70-80-90-100-110-120-130-140-150-160-170-180-190-200 Amps

For motor speed, the segments are:

0-0.5-1-1.5-2-2.5-3-3.5-4-4.5-5-5.5-6-6.5-7-7.5-8-8.5-9-9.5-10 RPM

For voltage, the segments are:

0-1-2-3-4-5-6-7-8-9-10-11-12-13-14-15-16-17-18-19-20 Volts

To save time during calibration, the calibration is performed for every other segment and the middle segments are calculated by taking an average of the surrounding calibration values. The exception is the first point, which cannot be calibrated because its value is zero; therefore, the second point is calibrated and its calibration value is stored in the first location also.

For example, for current, the segments to be calibrated are:

10,20,40,60,80,100,120,140,160,180,200 Amps.

Then, the 10 Amps calibration value is copied to 0 Amp calibration value.

Finally, the values for:

30,50,70,90,110,130,150,170,190 Amps, are calculated from the two values around them (average).

The same process is done for the output values (demand) and the input values (feedback) and the two sets are stored separately. The demand values are the ones used to tell the power supply what current to output. The feedback values are used to adjust the measured current from the shunt. The similar analogy applies to motor speed. Only voltage does not have the demand calibration because it is dependent on the physical setup and the current demand. However, the voltage feedback is calibrated and it measures the voltage across the arc gap.

Once calibrated, all of the calibration tables are stored in a non-volatile memory and are used all the time except when calibrating. Therefore, it is important to have the hardware and software calibration performed every time the hardware is changed or replaced and to have it done properly for every calibration point. Otherwise, the performance of the machine will be degraded or unacceptable.