

OWNER'S MANUAL

APPLIES TO KING COBRA TORCH
MODELS WITH PREFIX NO'S
141, 142, 143 & 144

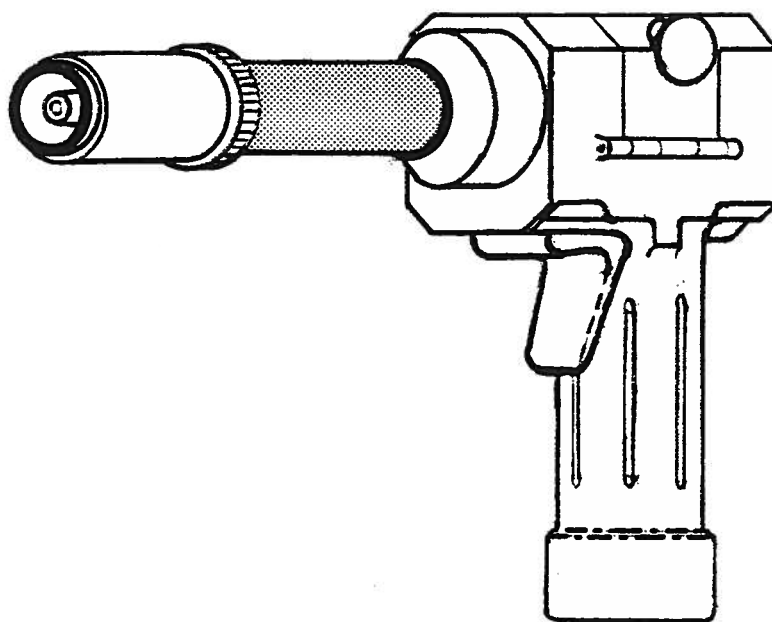

PRN #577

EFFECTIVE WITH SERIAL NO.

K3678

NWSA 550

P/N 091-0201

OCTOBER 1985

ADDITIONAL COPY PRICE-\$3.00

For your protection in the event of theft, loss or warranty service, please record the model & serial number of your King Cobra Torch, along with the date purchased and the name of the distributor. NOTE: Serial Number is stamped on torch block below idler roll.

MODEL NO. _____ SERIAL NO. _____
 DATE PURCHASED _____ DISTRIBUTOR _____

INDEX

	Page
SAFETY CONSIDERATIONS	
INTRODUCTION	1
SPECIFICATIONS	1
STRAIGHT & CURVED BARRELS	1
CONTACT TIPS, LINERS	1, 2
INTERCONNECTIONS—TORCH TO FEEDERS	3
OPERATION	4
STRAIGHT BARREL	4
DRIVE & IDLER ROLL REPLACEMENT	5
MAINTENANCE	6
TRUBLE SHOOTING	6, 7
OPTIONAL ACCESSORIES	
CONDUITS	7
AIR COOLED CUPS	8
MIG SPOT CUPS	8
HEAVY-DUTY CUPS—(#12 & #14)	8
SPRING LOADED CONTACT TIPS	8
OPTIONAL BARRELS	
HEAVY-DUTY WATER COOLED BARRELS	8
SPECIFICATIONS	8
GAS CUPS	9
CONTACT TIPS	9
AIR COOLED BARRELS	
STRAIGHT BARREL CONTACT TIPS, LINERS	9
CURVED BARRELS (45°) & (48°) CONTACT TIPS, LINERS	10
OPTIONAL KITS	10, 11
TORCH BARREL ASSEMBLIES (VISUAL PICTURES)	12, 13
KING COBRA EXPLODED VIEW & PARTS LIST	14, 15
ELECTRICAL CABLE ASSEMBLIES (7 PIN & 10 PIN)	16
3 FT, 6 FT, 10 FT LEAD ASSEMBLIES	16
AIR COOLED CURVED BARREL DRAWING & PARTS LIST	17
AIR COOLED STRAIGHT BARREL DRAWING & PARTS LIST	18
HEAVY-DUTY KING COBRA (500 I.P.M.) EXPLODED VIEW & PARTS	19
HEAVY-DUTY KING COBRA (500 I.P.M.) DRIVE ROLL INSTALLATION	20
SCHEMATICS	
COBRAMATIC CABINET	21
COBRAMATIC CHAMP	22
COBRAMATIC BRUTE	23
WARRANTY	24



SAFETY CONSIDERATIONS

ELECTRIC ARC WELDING EQUIPMENT

CAUTION: READ BEFORE ATTEMPTING INSTALLATION, OPERATION OR MAINTENANCE OF THIS EQUIPMENT.

1-1 INTRODUCTION

This equipment is intended for ultimate application by commercial/ industrial users and for operation by persons trained and experienced in the use and maintenance of welding equipment. Operation should not be undertaken without adequate training in the use of such equipment. Training is available from many public and private schools or similar facilities.

Safe practices in the installation, operation and maintenance of this equipment requires proper training in the art, a careful study of the information provided with the equipment, and the use of common sense. Rules for safe use are generally provided by suppliers of welding power sources, compressed gas suppliers and electrode suppliers. Careful compliance with these rules will promote safe use of this equipment.

The following Safety Rules cover some of the more generally found situation. READ THEM CAREFULLY. In case of any doubt, obtain qualified help before proceeding.

1-2. GENERAL PRECAUTIONS

A. Burn Prevention

ELECTRIC ARC WELDING PRODUCES HIGH INTENSITY HEAT AND ULTRA-VIOLET RADIANT ENERGY WHICH MAY CAUSE SERIOUS AND PERMANENT EYE DAMAGE AND WHICH MAY DAMAGE ANY EXPOSED SKIN AREAS.

Wear helmet with safety goggles or glasses with side shields underneath, appropriate filter lenses or plates (protected by clear cover glass). This is a **MUST** for welding or cutting, (and chipping) to protect the eyes from radiant energy and flying metal. Replace cover glass when broken, pitted, or spattered.

Medical first aid and eye treatment. First aid facilities and a qualified first aid person should be available for each shift unless medical facilities are close by for immediate treatment of flash burns of the eyes and skin burns.

Wear protective clothing — leather (or asbestos) gauntlet gloves, hat, and high safety-toe shoes. Button shirt collar and pocket flaps, and wear cuffless trousers to avoid entry of sparks and slag.

Avoid oily or greasy clothing. A spark may ignite them.

Flammable hair preparations should not be used by persons intending to weld or cut.

Hot metal such as electrode stubs and work pieces should never be handled without gloves.

Ear plugs should be worn when working on overhead or in a confined space. A hard hat should be worn when others work overhead.

B. Toxic Fume Prevention

Adequate ventilation. Severe discomfort, illness or death can result from fumes, vapors, heat, or oxygen enrichment or depletion that welding (or cutting) may produce. Prevent them with adequate ventilation. NEVER ventilate with oxygen.

Lead-, cadmium-, zinc-, mercury-, beryllium-bearing and similar materials, when welded or cut may produce harmful concentrations of toxic fumes. Adequate local exhaust ventilation must be used, or each person in the area as well as the operator

must wear an air-supplied respirator. For beryllium, both must be used.

Metals coated with or containing materials that emit toxic fumes should not be heated unless coating is removed from the work surface, the area is well ventilated, or the operator wears an air-supplied respirator.

Work in a confined space only while it is being ventilated and, if necessary, while wearing an air-supplied respirator.

Gas leaks in a confined space should be avoided. Leaked gas in large quantities can change oxygen concentration dangerously. Do not bring gas cylinders into a confined space.

Leaving confined space, shut OFF gas supply at source to prevent possible accumulation of gases in the space if downstream valves have been accidentally opened or left open. Check to be sure that the space is safe before re-entering it.

Vapors from chlorinated solvents can be decomposed by the heat of the arc (or flame) to form PHOSGENE, a highly toxic gas, and other lung and eye irritating products. The ultraviolet (radiant) energy of the arc can also decompose trichloroethylene and perchloroethylene vapors to form phosgene. **DO NOT WELD** or cut where solvent vapors can be drawn into the welding or cutting atmosphere or where the radiant energy can penetrate to atmospheres containing even minute amounts of trichloroethylene or perchloroethylene.

C. Fire and Explosion Prevention

Causes of fire and explosion are: combustibles reached by the arc, flame, flying sparks, hot slag or heated material; misuse of compressed gases and cylinders; and short circuits.

BE AWARE THAT flying sparks or falling slag can pass through cracks, along pipes, through windows or doors, and through wall or floor openings, out of sight of the goggled operator. Sparks and slag can fly many feet.

To prevent fires and explosion:

Keep equipment clean and operable, free of oil, grease, and (in electrical parts) of metallic particles that can cause short circuits.

If combustibles are in area, do NOT weld or cut. Move the work if practicable, to an area free of combustibles. Avoid paint spray rooms, dip tanks, storage areas, ventilators. If the work cannot be moved, move combustibles at least 35 feet away out of reach of sparks and heat; or protect against ignition with suitable and snug-fitting, fire-resistant covers or shields.

Walls touching combustibles on opposite sides should not be welded on (or cut). Walls, ceilings, and floor near work should be protected by heat-resistant covers or shields.

Fire watcher must be standing by with suitable fire extinguishing equipment during and for some time after welding or cutting if:

- appreciable combustibles (including building construction) are within 35 feet.
- appreciable combustibles are further than 35 feet but can be ignited by sparks.

E. User Responsibilities

Follow all Safety Rules.

Remove leaky or defective equipment from service immediately for repair. Read and follow user manual instructions.

F. Leaving Equipment Unattended

Close gas supply at source and drain gas.

G. Rope Staging-Support

Rope staging-support should not be used for welding or cutting operation; rope may burn.

1-3. ARC WELDING

Comply with precautions in 1-1, 1-2, and this section. Arc Welding, properly done, is a safe process, but a careless operator invites trouble. The equipment carries high currents at significant voltages. The arc is very bright and hot. Sparks fly, fumes rise, ultraviolet and infrared energy radiates, weldments are hot, and compressed gases may be used. The wise operator avoids unnecessary risks and protects himself and others from accidents.

A. Burn Protection

Comply with precautions in 1-2.

The welding arc is intense and visibly bright. Its radiation can damage eyes, penetrate lightweight clothing, reflect from light-colored surfaces, and burn the skin and eyes. Skin burns resemble acute sunburn, those from gas-shielded arcs are more severe and painful. DON'T GET BURNED; COMPLY WITH PRECAUTIONS.

1. Protective Clothing

Wear long-sleeve clothing in addition to gloves, hat, and shoes. As necessary, use additional protective clothing such as leather jacket or sleeves, flame-proof apron, and fire-resistant leggings. Avoid outer garments of untreated cotton.

Bare skin protection. Wear dark, substantial clothing. Button collar to protect chest and neck and button pockets to prevent entry of sparks.

2. Eye and Head Protection

Protect eyes from exposure to arc. Eyes may be damaged by radiant energy when exposed to the electric arc even when not looking in the direction of the arc. Never look at an electric arc without protection.

Welding helmet or shield containing a filter plate shade no. 12 or denser must be used when welding. Place over face before striking arc.

Protect filter plate with a clear cover plate.

Cracked or broken helmet or shield should NOT be worn; radiation can pass through to cause burns.

Cracked, broken, or loose filter plates must be replaced IMMEDIATELY. Replace clear cover plate when broken, pitted, or spattered.

Flash goggles with side shields MUST be worn under the helmet to give some protection to the eyes should the helmet not be lowered over the face before an arc is struck. Looking at an arc momentarily with unprotected eyes (particularly a high intensity gas-shielded arc) can cause a retinal burn that may leave a permanent dark area in the field of vision.

3. Protection of Nearby Personnel

Enclose the welding area. For production welding, a separate room or enclosed bay is best. In open areas, surround the operation with low-reflective, non-combustible screens or panels. Allow for free air circulation, particularly at floor level.

Viewing the weld. Provide face shields for all persons who will be looking directly at the weld.

Others working in area. See that all persons are wearing flash goggles.

Before starting to weld, make sure that screen flaps or bay doors are closed.

B. Toxic Fume Prevention

Comply with precautions in 1-2B.

Generator engine exhaust must be vented to the outside air. Carbon monoxide can kill.

C. Fire and Explosion Prevention

Comply with precautions in 1-2C.

Equipment's rated capacity. Do not overload arc welding equipment. It may overheat cables and cause a fire.

Loose cable connections may overheat or flash and cause a fire.

Never strike an arc on a cylinder or other pressure vessel. It creates a brittle area that can cause a violent rupture or lead to such a rupture later under rough handling.

D. Compressed Gas Equipment

Comply with precautions in 1-2D.

E. Shock Prevention

Exposed electrically hot conductors or other bare metal in the welding circuit, or in ungrounded, electrically-HOT equipment can fatally shock a person whose body becomes a conductor. DO NOT STAND, SIT, LIE, LEAN ON, OR TOUCH a wet surface when welding, without suitable protection.

To protect against shock:

Keep body and clothing dry. Never work in damp area without adequate insulation against electrical shock. Stay on a dry duckboard, or rubber mat when dampness or sweat can not be avoided. Sweat, sea water, or moisture between body and an electrically HOT part—or grounded metal—reduces the body surface electrical resistance, enabling dangerous and possibly lethal currents to flow through the body.

1. Grounding the Equipment

When installing, connect the frames of each unit such as welding power source, control, work table, and water circulator to the building ground. Conductors must be adequate to carry ground currents safely. Equipment made electrically HOT by stray current may shock, possibly fatally. Do NOT GROUND to electrical conduit, or to a pipe carrying ANY gas or a flammable liquid such as oil or fuel.

Three-phase connection. Check phase requirement of equipment before installing. If only 3-phase power is available, connect single-phase equipment to only two wires of the 3-phase line. Do NOT connect the equipment ground lead to the third (live) wire, or the equipment will become electrically HOT—a dangerous condition that can shock, possibly fatally.

Before welding, check ground for continuity. Be sure conductors are touching bare metal of equipment frames at connections.

If a line cord with a ground lead is provided with the equipment for connection to a switchbox, connect the ground lead to the grounded switchbox. If a three-prong plug is added for connection to a grounded mating receptacle, the ground lead must be connected to the ground prong only. If the line cord comes with a three-prong plug, connect to a grounded mating receptacle. **Never remove the ground prong from a plug, or use a plug with a broken off ground prong.**

2. Connectors

Fully insulated lock-type connectors should be used to join welding cable lengths.

3. Cables

Frequently inspect cables for wear, cracks and damage. IMMEDIATELY REPLACE those with excessively worn or damaged insulation to avoid possibly-lethal shock from bared cable. Cables with damaged areas may be taped to give resistance equivalent to original cable.

Keep cable dry, free of oil and grease, and protected from hot metal and sparks.

4. Terminals and Other Exposed Parts

Terminals and other exposed parts of electrical units should have insulating covers secured before operation.

5. Electrode Wire

Electrode wire becomes electrically HOT when the power switch of gas metal-arc welding equipment is ON and welding gun trigger is pressed. Keep hands and body clear of wire and other HOT parts.

- c. openings (concealed or visible) in floors or walls within 35 feet may expose combustibles to sparks.
- d. combustibles adjacent to walls, ceilings, roofs, or metal partitions can be ignited by radiant or conducted heat.

Hot work permit should be obtained before operation to ensure supervisor's approval that adequate precautions have been taken.

After work is done, check that area is free of sparks, glowing embers, and flames.

An empty container that held combustibles, or that can produce flammable or toxic vapors when heated, must never be welded on or cut, unless container has first been cleaned in accordance with industry standards.

This includes: a thorough steam or caustic cleaning (or a solvent or water washing, depending on the combustible's solubility) followed by purging and inerting with nitrogen or carbon dioxide, and using protective equipment.

Waterfilling just below working level may substitute for inerting.

A container with unknown contents should be cleaned (see paragraph above). Do NOT depend on sense of smell or sight to determine if it is safe to weld or cut.

Hollow castings or containers must be vented before welding or cutting. They can explode.

Explosive atmospheres. Never weld or cut where the air may contain flammable dust, gas, or liquid vapors (such as gasoline).

D. Compressed Gas Equipment

The safe handling of compressed gas equipment is detailed in numerous industry publications. The following general rules cover many of the most common situations.

1. Pressure Regulators

Regulator relief valve is designed to protect only the regulator from overpressure; it is not intended to protect any downstream equipment. Provide such protection with one or more relief devices.

Never connect a regulator to a cylinder containing gas other than that for which the regulator was designed.

Remove faulty regulator from service immediately for repair (first close cylinder valve). The following symptoms indicate a faulty regulator:

Leaks—if gas leaks externally.

Excessive Creep—if delivery pressure continues to rise with downstream valve closed.

Faulty Gauge—if gauge pointer does not move off stop pin when pressurized, nor returns to stop pin after pressure release.

Repair. Do NOT attempt repair. Send faulty regulators for repair to manufacturer's designated repair center, where special techniques and tools are used by trained personnel.

2. Cylinders

Cylinders must be handled carefully to prevent leaks and damage to their walls, valves, or safety devices:

Avoid electrical circuit contact with cylinders including third rails, electrical wires, or welding circuits. They can produce short circuit arcs that may lead to a serious accident. (See 1-3C)

ICC or DOT marking must be on each cylinder. It is an assurance of safety when the cylinder is properly handled.

Identifying gas content. Use only cylinders with name of gas marked on them; do not rely on color to identify gas content. Notify supplier if unmarked. NEVER DEFACE or alter name, number, or other markings on a cylinder. It is illegal and hazardous.

Empties: Keep valves closed, replace caps securely; mark MT; keep them separate from FULLS and return promptly.

Prohibited use. Never use a cylinder or its contents for other than its intended use, NEVER as a support or roller.

Locate or secure cylinders so they cannot be knocked over.

Passageways and work areas. Keep cylinders clear of areas where they may be stuck.

Transporting cylinders. With a crane, use a secure support such as a platform or cradle. Do NOT lift cylinders off the ground by their valves or caps, or by chains, slings, or magnets.

Do NOT expose cylinders to excessive heat, sparks, slag, and flame, etc. that may cause rupture. Do not allow contents to exceed 55 °C (130 °F.) Cool with water spray where such exposure exists.

Protect cylinders particularly valves from bumps, falls, falling objects, and weather. Replace caps securely when moving cylinders.

Stuck valve. Do NOT use a hammer or wrench to open a cylinder valve that can not be opened by hand. Notify your supplier.

Mixing gases. Never try to mix any gases in a cylinder.

Never refill any cylinder.

Cylinder fittings should never be modified or exchanged.

3. Hose

Prohibited use. Never use hose other than that designed for the specified gas. A general hose identification rule is: red for fuel gas, green for oxygen, and black for inert gases.

Use ferrules or clamps designed for the hose (not ordinary wire or other substitute) as a binding to connect hoses to fittings.

No copper tubing splices. Use only standard brass fittings to splice hose.

Avoid long runs to prevent kinks and abuse. Suspend hose off ground to keep it from being run-over, stepped on, or otherwise damaged.

Coil excess hose to prevent kinks and tangles.

Protect hose from damage by sharp edges, and by sparks, slag, and open flame.

Examine hose regularly for leaks, wear, and loose connections. Immerse pressured hose in water; bubbles indicate leaks.

Repair leaky or worn hose by cutting area out and splicing. Do NOT use tape.

4. Proper Connections

Clean cylinder valve outlet of impurities that may clog orifices and damage seats before connecting regulator. Except for hydrogen, crack valve momentarily, pointing outlet away from people and sources of ignition. Wipe with a clean lintless cloth.

Match regulator to cylinder. Before connecting, check that the regulator label and cylinder marking agree, and that the regulator inlet and cylinder outlet match. NEVER CONNECT a regulator designed for a particular gas or gases to a cylinder containing any other gas.

Tighten connections. When assembling threaded connections, clean and smooth seats where necessary. Tighten. If connection leaks, disassemble, clean, and retighten using properly fitting wrench.

Adapters. Use a CGA adapter (available from your supplier) between cylinder and regulator, if one is required. Use two wrenches to tighten adapter marked RIGHT and LEFT HAND threads.

Regulator outlet (or hose) connections may be identified by right hand threads for oxygen and left hand threads (with grooved hex on nut or shank) for fuel gas.

5. Pressurizing Steps:

Drain regulator of residual gas through suitable vent before opening cylinder (or manifold valve) by turning adjusting screw in (clockwise). Draining prevents excessive compression heat at high pressure seat by allowing seat to open on pressurization. Leave adjusting screw engaged slightly on single-stage regulators. Stand to side of regulator while opening cylinder valve.

Open cylinder valve slowly so that regulator pressure increases slowly. When gauge is pressurized (gauge reaches regulator maximum) leave cylinder valve in following position: For oxygen, and inert gases, open fully to seal stem against possible leak. For fuel gas, open to less than one turn to permit quick emergency shutoff.

Use pressure charts (available from your supplier) for safe and efficient, recommended pressure settings on regulators.

Check for leaks on first pressurization and regularly thereafter. Brush with soap solution. Bubbles indicate leak. Clean off soapy water after test; dried soap is combustible.

6. Safety Devices

Safety devices such as interlocks and circuit breakers should not be disconnected or shunted out.

Before installation, inspection, or service of equipment, shut OFF all power and remove line fuses (or lock or red-tag switches) to prevent accidental turning ON of power. Disconnect all cables from welding power source, and pull all 115 volts line-cord plugs.

Do not open power circuit or change polarity while welding. If, in an emergency, it must be disconnected, guard against shock burns, or flash from switch arcing.

Leaving equipment unattended. Always shut OFF and disconnect all power to equipment.

Power disconnect switch must be available near the welding power source.



INTRODUCTION

This manual details the installation and operation of your King Cobra Torch with the Cobramatic Cabinet or the Champ/Brute Cobramatic open frame Wire Feeders.

King Cobra Torches with Model No. Prefix 118, 133 are used with 7 pin Amphenol Cobramatic Cabinets with Model No. Prefix 150 only.

King Cobra Torches with Model No. Prefix 141, 142, 143, 144 are used with 10 pin Amphenol Champ/Brute Cobramatic Model No. 151; or, by utilizing 10 pin to 7 pin Amphenol adapter P/N 843-0190, can be used with Cobramatic Cabinet Model No. Prefix 150.

SPECIFICATIONS

Motor/Gear Box	Wire Capacity - All Types	Max IPM	Max M/Min	Max Amps
Standard	.030 in-1/16 in (.8mm-1.6mm)	700	17.8	
Heavy-Duty	.030 in-3/32 in (.8mm-2.4mm)	500	12.7	
High Speed	.030 in-3/64 in (.8mm-1.2mm)	1000	25.4	

Water Cooled Barrels (See pages 12 & 13 for visual pictures)

Std. Straight	.030 in-1/16 in (.8mm-1.6mm)			400
Curved	.030 in-1/16 in (.8mm-1.6mm)			400
Heavy-Duty	.030 in-1/16 in (.8mm-1.6mm)			750
Air Cooled Cup (incorporates water cooled barrel)				
Curved & St.	.030 in-1/16 in (.8mm-1.6mm)			300

Note: All above barrels are 100% duty cycle.

Note: All King Cobra Barrels and Cups, not water cooled, are rated at 200 amps 50% duty cycle.

Note: All water cooled straight & curved barrels with Heavy-Duty Cups are rated at 500 amps 100% duty cycle. See Optional Accessories for part numbers. (See page 8)

Contact Tips For Straight And Curved Barrel Assemblies

Wire Size	Tip I.D.	Arc	Tip Length	Part No.
.030 in/.8mm	.036 in/.9mm	Spray	1-5/8 in/41.3mm	621-0155
		Short	1-7/8 in/47.6mm	621-0173
.030 in/.8mm	.040 in/1.0mm	Spray	1-5/8 in/41.3mm	621-0158
		Short	1-7/8 in/47.6mm	621-0165
.035 in/.9mm	.044 in/1.1mm	Spray	1-5/8 in/41.3mm	621-0157
		Short	1-7/8 in/47.6mm	621-0166
.045 in/1.2mm	.053in/1.35mm	Spray	1-5/8 in/41.3mm	621-0161
		Short	1-7/8 in/47.6mm	621-0167
.052 in/1.4mm	.060in/1.5mm	Spray	1-5/8 in/41.3mm	621-0162
		Short	1-7/8 in/47.6mm	621-0168
.063 in/1.6mm	.075in/1.9mm	Spray	1-5/8 in/41.3mm	*621-0163
		Short	1-7/8 in/47.6mm	621-0169
.063 in/1.6mm	.085in/2.16mm	Spray	1-5/8 in/41.3mm	621-0164
.093 in/2.3mm	.105in/2.4mm	Spray	1-5/8 in/41.3mm	621-0213
.093 in/2.3mm	.113in/2.8mm	Spray	1-5/8 in/41.3mm	621-0215

*Standard - Furnished With Torch

SPECIFICATIONS (Continued)

King Cobra Straight Barrel Liners -(Teflon is recommended for alum. wire)

Barrel Part No.	Barrel Length	Liner Material	Liner Description	Wire Size	Part No.
001-1765	6"/152.4mm	White	.052ID X 6.06"lg	.030-.035"	615-0231
			Teflon	1.2mm X 154.0mm	.8 - .9mm
		Teflon	.084ID X 6.06"lg	.045-.063"	615-0235
			2.0mm X 154.0mm	1.2mm-1.6mm	
			.105ID X 6.06"lg	.093"	615-0293
			2.4mm X 154.0mm	2.3mm	
001-1766	12"/304.8mm	White	.052ID X 12.25"lg	.030-.035"	615-0232
			Teflon	1.2mm X 310.0mm	.8mm - .9mm
		Teflon	.084ID X 12.25"lg	.045-.063"	615-0236
			2.0mm X 310.2mm	1.2mm-1.6mm	
			.105ID X 12.25"lg	.093"	615-0294
			2.4mm X 310.0mm	2.3mm	
001-1767	18"/457.2mm	White	.052ID X 18.25"lg	.030-.035"	615-0233
			Teflon	1.2mm X 457.2mm	.8mm - .9mm
		Teflon	.084ID X 18.25"lg	.045-.063"	615-0237
			2.0mm X 457.2mm	1.2mm-1.6mm	
			.105ID X 18.25"lg	.093"	615-0295
			2.4mm X 457.2mm	2.3mm	
001-1768	29"/736.6mm	White	.052ID X 29.56"lg	.030-.035"	615-0234
			Teflon	1.2mm X 750.8mm	.8mm - .9mm
		Teflon	.084ID X 29.56"lg	.045-.062"	615-0238
			2.0mm X 750.8mm	1.2mm-1.6mm	
			.105ID X 29.56"lg	.093"	615-0296
			2.4mm X 750.8mm	2.3mm	

King Cobra Curved Barrel Liners -(Spiral steel recommended for steel wire)

001-1750	6"/152.4mm	White	.052ID X 7.56" lg	.030-.035"	615-0179
			Teflon	1.2mm X 192.0mm	.8mm - .9mm
		Teflon	.084ID X 7.56" lg	.045-.062"	615-0182
			2.0mm X 192.0mm	1.2mm-1.6mm	
			.105ID X 7.56" lg	.093"	615-0297
			2.4mm X 192.0mm	2.3mm	
001-1751	12"/304.8mm	White	.114ID X 7.56" lg	.030-.063"	615-0223
			Spiral Steel	2.8mm X 192.0mm	.8mm-1.6mm
		Teflon	.052ID X 13.31"lg	.030-.035"	615-0180
			1.2mm X 338.0mm	.8mm - .9mm	
			.084ID X 13.31"lg	.045-.063"	615-0183
			2.0mm X 338.0mm	1.2mm-1.6mm	
			.105ID X 13.31"lg	.093"	615-0298
			2.4mm X 338.0mm	2.3mm	
001-1752	18"/457.2mm	White	.114ID X 13.31"lg	.030-.063"	615-0224
			Spiral Steel	2.8mm X 338.0mm	.8mm-1.6mm
		Teflon	.052ID X 19.31"lg	.030-.035"	615-0181
			1.2mm X 490.5mm	.8mm - .9mm	
			.084ID X 19.31"lg	.045-.063"	615-0184
			2.0mm X 490.5mm	1.2mm-1.6mm	
			.105ID X 19.31"lg	.093"	615-0299
			2.4mm X 490.5mm	2.3mm	
		Spiral Steel	.114ID X 19.31"lg	.030-.063"	615-0225
			2.8ID X 490.5mm	.8mm-1.6mm	

Interconnections - Torch to Cobramatic Cabinet

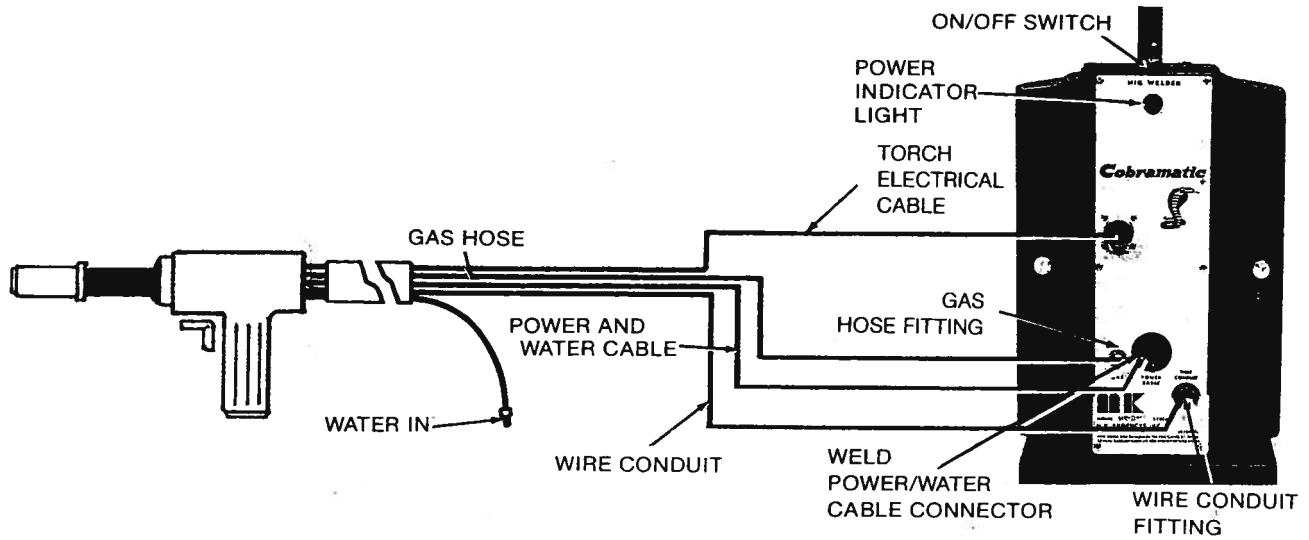

Interconnections - Torch to "Champ" & "Brute" Cobramatics

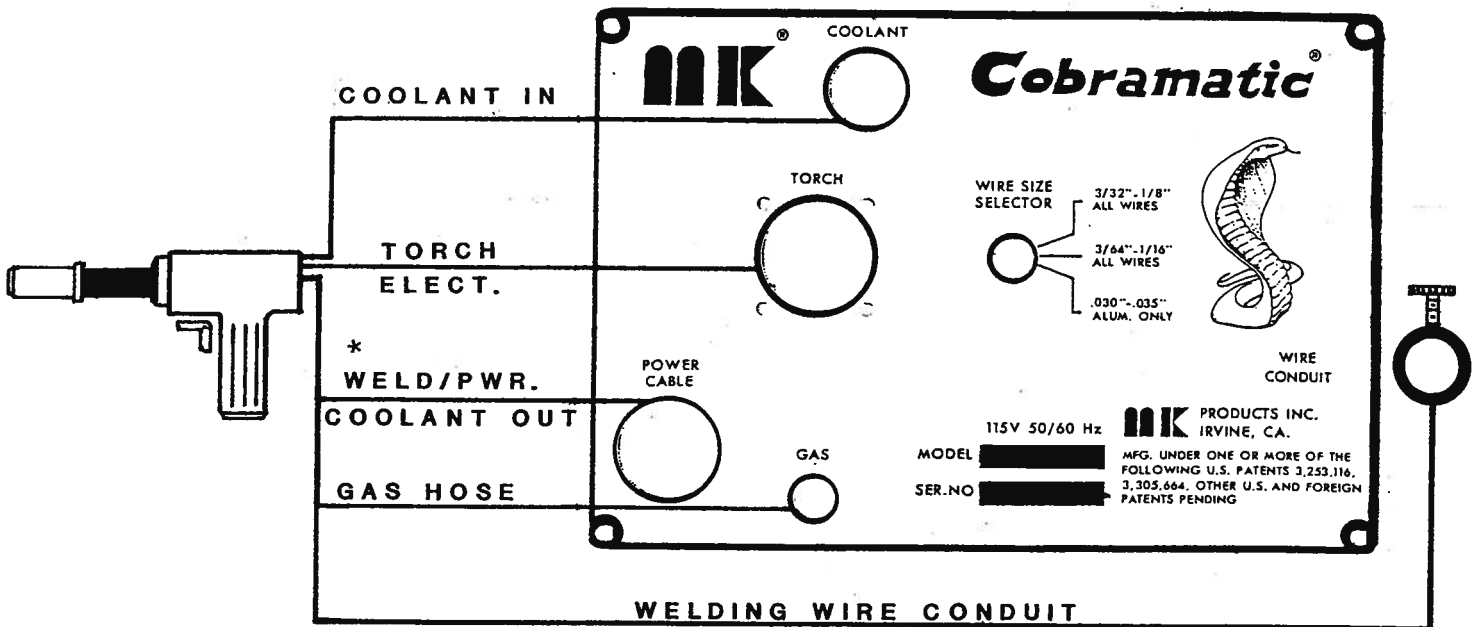

* Accessed through door on left-hand side.

OPERATION

1. Wire feed speed rate is controlled by 5-turn potentiometer located on the back end of the torch.
2. Idler roll pressure adjustment is accessed through door on left-hand side of torch.
3. For initial feeding of wire, engage pressure screw 1/2 - 1 turn only. Further tightening with Allen wrench may be necessary when using steel wire, after initial threading.
4. The torch trigger is so designed that when it is partially depressed, gas flow starts via the valve located in the torch body - prior to ignition of the welding arc. When the trigger is partially released (extinguishing the arc), gas flow continues until the trigger is fully released.
Built in Pre & Post gas flow.

Standard 6" Straight Barrel

CAUTION: DISCONNECT WELD POWER SOURCE

(See Pages 14 & 15 for item numbers listed below)

1. Contact Tip Removal, Item 84 - Use tip wrench P/N 931-0002 which eliminates disassembling cup from barrel to change tips.
2. Liner Removal, Item 101 - Pull trigger after removing tip and liner will follow wire out of barrel. See page 2 for proper liner.
3. Cup Removal, Item 96 - Unscrew cup nut, item 80 fully. Pull off cup with slight turning motion.
4. Cup Insulator, Item 81 - Unscrews from barrel counterclockwise. On reassembly, make sure insulator clears gas ports on tip holder section of barrel.
5. Removal of barrel requires disassembly of left-hand handle and loosening clamping screws (2), item 35.

OPERATION (Continued)

Drive And Idler Roll Replacement

NOTE: Refer to exploded view page 14 for item numbers listed below.

Tools Required: Allen Wrench Set
2 ea. Small slot type screwdrivers
3/8 Open End Wrench

1. Disconnect torch electrical cable from wire feeder.
2. Remove trigger pin, item 48 and trigger, item 49.
3. Disassemble left-hand handle, item 60, by removing Allen screws, item 61, 64, 30.
4. Depending on type of drive rolls in your King Cobra Torch, proceed as follows:

A. Knurled Drive and Idler Roll Removal

1. Restrain gear under drive roll, and remove self-locking nut above drive roll.
2. Using two (2) screwdrivers, pry drive roll and drive gear from drive shaft.
3. Disassembly of idler roll requires removing screw threaded into idler arm. NOTE: Idler roll & gear are a one-piece assembly.)

B. Grooved Drive Roll Removal

1. Restrain existing drive roll by inserting 1/16" Allen wrench into hole located on drive roll just below groove, and remove nut above drive roll.
2. Using two (2) screwdrivers, pry drive roll from drive shaft.
3. Disassembly of idler roll requires removing screw threaded into idler arm.
4. NOTE: Make sure to install grooved idler roll with wire size identification facing up to insure groove in proper position.
5. Taking care to clear Micro Switch actuator arm, fit left-hand handle in place and reassemble handle screws.
6. Reassemble trigger.

MAINTENANCE

Maintenance of your King Cobra Torch will normally consist of a general cleaning of the wire guide system, including tubes, drive rolls and conduit at regular intervals.

Remove spatter buildup from inside of cup with a hardwood stick.

<u>Part Number</u>	<u>Maintenance Tools</u>
835-0003	Gear box lubricant 8 oz. jar
835-0005	Safety solvent for installing water power boot
921-0022	Allen wrench set
921-0029	Allen wrench - universal ball type
931-0584	Gas valve removal tool
931-0002	King Cobra Torch tip wrench
835-0006	Super lube 'O'ring lubricant

Coolant Recommendations

1. Use a name-brand additive, which does not contain reactive sulphur or chlorine and does not react with copper, brass or aluminum.
2. Check coolant periodically to remain within limits of the following:
 - A. Coolant Flow Rate - 1 quart/minute at 35 p.s.i.
 - B. Resistivity - > 10K ohms/centimeter
 - C. Ph Range - 5.5 - 8.5
 - D. Particle Size - < .005"

TROUBLE SHOOTING

Problem: Wire Burnback

Causes:

Solutions:

1. Wrong size contact tip-----See Specifications, Page 1 for proper size.
2. Too low wire feed-----Increase
3. Too high welding voltage---Decrease
4. Torch idler roll tension incorrect-----See Operation, Page 5
5. Lack of weld ground-----Check for continuity with work piece.

Problem: Torch Motor Runs One Speed Only

1. Potentiometer failure-----Check with voltmeter
See Schematic, Page 21,22, or 23
2. Short in torch electric cable-----Check with voltmeter
See Schematic, Page 21,22, or 23
3. Torch motor speed control faulty-----Check voltage of torch motor speed control (P/N 177-0500) with wire feed speed control potentiometer wide open and

TROUBLE SHOOTING (Continued)

gun trigger depressed a reading of 24 to 27 VAC should register across terminals H and A and 24 VDC across terminals T and W.

Problem: Torch Motor Erratic or Inoperative

1. Short circuit in torch
Micro Switch-----Disengage feeder 115 VAC power & check pins with meter
2. Torch motor not receiving
24 VDC-----Check for voltage reading at 24 VDC torch motor
-----Check continuity on All wires from torch to wire feeder
-----Check potentiometer with ohmmeter

Problem: Loss of Weld Current

1. Lack of weld ground-----Check for continuity with work piece
2. Break in water/power cable--Check for continuity

Problem: Poor Gas/Water Flow

1. Check barrel insulator P/N 261-0049. This insulator must be correctly installed on the contact tube with gas ports exposed for proper gas coverage.
2. Gas cup must be fully seated on the cup insulator P/N 261-0049 and secured with the cup retaining nut.

OPTIONAL ACCESSORIES

Conduits

	<u>Length</u>	<u>Part Number</u>
Standard conduit with additional protective cover	15 Ft/4.5 M	001-0774
	25 Ft/7.6 M	001-0775
	30 Ft/9.0 M	001-0776
	50 Ft/15.0 M	001-0777
Flat Spiral Conduit for Steel & Cored Wire	15 Ft/4.5 M	615-0208
	25 Ft/7.6 M	615-0216
	30 Ft/9.0 M	615-0217
	50 Ft/15.0 M	615-0218

OPTIONAL ACCESSORIES (Continued)

Air Cooled Cups

Cup Size	Cup I.D.	Cup Length	Part Number
No. 6	3/8in/9.5mm	1.43in/36.5mm	621-0170
No. 8	1/2in/12.7mm	1.43in/36.5mm	621-0159
No. 10	5/8in/15.9mm	1.43in/36.5mm	621-0160

Use of the above air cooled Gas Cups on either the straight or curved barrel assemblies requires the addition of a Gas Cup nut P/N 449-0193 and a Gas Cup adapter P/N 621-0101.

MIG Spot Cups

Description	Cup Size	Part No.
Inside Corner	#10	621-0174
Outside Corner	#10	621-0175
Flat	#10	621-0176
Flat - Seam	#10	621-0177
Flat - Heavy-Duty	#18	621-0178

NOTE: Straight and Curved Barrels require Adapter P/N 621-0101 and gas cup nut P/N 449-0193 to use above Spot Cups.

Heavy-Duty Cups

	Part No.
#12	621-0190
#14	621-0191
Cup Retainer Nut	431-1164
Cup Insulator	261-0388
(Included with P/N 621-0190 and 621-0191)	
Barrel Cup Insulator	261-0389

NOTE: When using heavy duty cups, it is necessary to change cup retainer nut and insulator.

Above Heavy-Duty Cups can only be used on straight barrels P/N 001-1765, 001-1766, 001-1767, and curved barrels 001-1750, 001-1751, 001-1752.

Spring Loaded Contact Tips

Part No.	Tip I.D.	Tip Length
621-0200	.036"/.99 mm	1-5/8"/41.3 mm lg
621-0201	.040"/1.0 mm	1-5/8"/41.3 mm lg
621-0202	.044"/1.1 mm	1-5/8"/41.3 mm lg
621-0203	.053"/1.4 mm	1-5/8"/41.3 mm lg
621-0204	.060"/1.5 mm	1-5/8"/41.3 mm lg
621-0205	.075"/1.9 mm	1-5/8"/41.3 mm lg
621-0206	.113"/2.8 mm	1-5/8"/41.3 mm lg

Heavy-Duty Water Cooled Barrels**

P/N 001-0670	- #12 Cup (3/4" / 19.1mm)
P/N 001-0671	- #14 Cup (7/8" / 22.2mm)
P/N 001-0672	- #16 Cup (1" / 25.4mm)

Specifications

Wire capacity	Duty Cycle		Used On
.030 - 1/16 (.8mm - 1.6mm)	Water Cooled 750 Amps @ 100%	Non-Water Cooled 200 Amps @ 50%	King Cobra, Mini Bug Machine Torches
All Wires			

** See Page 12 for visual picture and pages 14 & 15 for exploded view and parts list.

OPTIONAL ACCESSORIES (Continued)

Heavy-Duty Water Cooled Gas Cups

Size	Cup I.D.	Cup No.	Gas Diffuser No.
12	3/4"/19.0mm	621-0094	* 431-0779
14	7/8"/22.2mm	621-0095	* 431-0780
16	1"/25.4 mm	621-0096	* 431-0781

* Order separate from cup
(Gas Diffuser screws onto Contact Tip)

Contact Tips For
Heavy-Duty Water Cooled Barrel

Wire Size	Tip I.D.	Arc	Tip Length	Part No.
.030/.8mm	.040/1.0mm	Spray	1-5/8"/41.3mm	621-0020
		Short	1-7/8"/47.6mm	621-0035
.035/.9mm	.044/1.1mm	Spray	1-5/8"/41.3mm	621-0021
		Short	1-7/8"/47.6mm	621-0036
.045/1.2mm	.053/1.4mm	Spray	1-5/8"/41.3mm	621-0022
		Short	1-7/8"/47.6mm	621-0037
.052/1.3mm	.060/1.5mm	Spray	1-5/8"/41.3mm	621-0027
		Short	1-7/8"/47.6mm	621-0038
.063/1.6mm	.075/1.9mm	Spray	1-5/8"/41.3mm	* 621-0023
		Short	1-7/8"/47.6mm	621-0039
.063/1.6mm	.085/2.2mm	Spray	1-5/8"/41.3mm	621-0024

*Standard furnished with Torch
Note: All contact tips stamped with Tip I.D.

Air Cooled Barrels

Specifications for Straight & Curved Barrels - Air

Wire Capacity	Water Cooled	Non-Water Cooled
.030-1/16 (.8mm - 1.6mm)	300 Amps 30 Volts 100% Duty Cycle	200 Amps 25 Volts 50% Duty Cycle
All Types		

Air Cooled Straight Barrel: _____ P/N 001-1880

Air Cooled Curved Barrels:
450 _____ P/N 001-1788
480 _____ P/N 001-1807

Spray Arc Contact Tips & Teflon Liners**
For Air Cooled Straight Barrel

Spray Arc Contact Tips			Teflon Liners	
Part No.	Wire Size	Tip I.D.	Part No.	Wire Size
621-0111	.030/.8mm	.040/1.0mm	615-0244	.035/.9mm
621-0112	.035/.9mm	.044/1.1mm		
621-0113	.045/1.2mm	.053/1.4mm	615-0245	.045-.063
621-0114	3/64-.052 (1.2-1.4mm)	.060/1.5mm		(1.2-1.6mm)
621-0115	.063/1.6mm	.075/1.9mm		
621-0116	.063/1.6mm	.085/2.2mm		

** See page 18 for drawing and parts list.

OPTIONAL ACCESSORIES (Continued)

Spray Arc Contact Tips & Teflon Liners**
For Air Cooled Curved Barrel (45°)

Spray Arc Contact Tips			Teflon Liners	
Part No.	Wire Size	Tip I.D.	Part No.	Wire Size
621-0103	.030/.8mm	.036/.99mm	615-0244	.030-.035
621-0104	.030/.8mm	.040/1.0mm		(.8mm-.9mm)
621-0105	.035/.9mm	.044/1.1mm		
621-0106	3/64-.045 (1.2mm)	.053/1.4mm	615-0245	.045-.063 (1.2-1.6mm)
621-0107	3/64-.052 (1.2-1.4mm)	.060/1.5mm		
621-0108	.063/1.6mm	.075/1.9mm		
621-0109	.063/1.6mm	.085/2.2mm		

Spray Arc Contact Tips & Teflon Liners**
For Air Cooled Curved Barrel (48°)

Spray Arc Contact Tips			Teflon Liners	
Part No.	Wire Size	Tip I.D.	Part No.	Wire Size
621-0218	.030/.8mm	.036/.99mm	615-0244	.030-.035
621-0219	.030/.9mm	.040/1.0mm		(.8mm-.9mm)
621-0220	.035/.9mm	.044/1.1mm		
621-0221	3/64-.045 (1.2mm)	.053/1.4mm	615-0245	.045-.063 (1.2-1.6mm)
621-0222	3/64-.052 (1.2-1.4mm)	.060/1.5mm		
621-0223	.063/1.6mm	.075/1.9mm		
621-0224	.063/1.6mm	.085/2.2mm		

** See page 17 for drawing and parts list.

OPTIONAL KITS

KING TORCH DRIVE ROLL KITS

Part No.	Description
005-0119	<u>Insul. Knurled Drive Roll Kit .030-1/16"(.8-1.6mm)</u> Consists of: Idler roll assembly P/N 511-0087, Drive roll assembly P/N 511-0064 (drive roll P/N 431-0873, spur gear 507-0211)**
005-0120	<u>Insul. 'V' Groove Drive Roll Kit -.035"/.9 mm dia. wire</u> Consists of: Idler roll assembly P/N 511-0071,* and Drive roll assembly P/N 511-0065, (drive roll P/N 431-0874) **
005-0121	<u>Insul. 'V' Groove Drive Roll Kit -.045"/1.2 mm dia. wire</u> Consists of: Idler roll assembly P/N 511-0071,* and Drive roll assembly P/N 511-0066 (drive roll P/N 431-0875) **
005-0122	<u>Insul. 'V' Groove Drive Roll Kit -.062"/1.6 mm dia. wire</u> Consists of: Idler roll assembly P/N 511-0071,* and Drive roll assembly P/N 511-0067 (drive roll P/N 431-0876) **

OPTIONAL ACCESSORIES (Continued)

- 005-0132 Insul. 'V' Groove Drive Roll Kit -.030"/.8 mm dia. wire
Consists of: Idler roll assembly P/N 511-0071,* and
Drive roll assembly P/N 511-0077 (drive roll
P/N 431-0878) **
- 005-0136 Insul. 'V' Groove Drive Roll Kit -.093"/2.3 mm dia. wire
Consists of: Idler roll P/N 511-0071,* Drive roll
assembly P/N 511-0082 (drive roll P/N 431-1140) and
Slave mtr. drive roll for .093 dia. wires P/N 511-0081
NOTE: P/N 005-0136 can only be used on King Cobra
Torch Model Prefix's 143, 144, and Cobramatics Champ
Model 151-001 and Brute Model 151-002 Wire Feeders.
- 005-0333 Insul. 'V' Groove Drive Roll Kit -.040"/1.00 mm dia. wire
Consists of: Idler roll assembly P/N 511-0071* and
Drive roll assembly P/N 511-0086 (drive roll
P/N 511-0085) **

* Idler roll assemblies P/N 511-0071 for 'V' Groove Drive Roll
Kits above consist of insulator sleeve P/N 261-0243, spacer
washers P/N 342-0083, hex hd. screw mod. P/N 431-1073, bearing
P/N 501-0207.

** Drive roll assemblies for kits above contain drive roll,
insulator P/N 261-0242 and insul. key P/N 421-0403.

NOTE: All insulated drive roll kits include plastic hex nut
P/N 350-0004, rear wire guide P/N 431-0888, front wire
guide P/N 431-1067. (Front wire guide P/N 431-1077 for
use with previous straight barrel design; see kit
instructions for proper identification.)

- 005-0124 5 Turn Pot Kit - King Torch
Consists of: S/A 5 Turn Pot P/N 003-0423, pot nut
P/N 261-0247, left hand handle assembly P/N 437-0058,
right hand handle P/N 437-0060 and related hardware.
- 005-0130 Self-Locking Gear Box Kit
Consists of: (2) Nylon 1/8" dia. ball P/N 303-0091,
gear housing P/N 431-0509, (2) ring gear P/N 507-0500
and lubricant P/N 835-0007.
- 005-0144 King Cobra Handle Kit for 5 Turn Pot.
Consists of left hand handle assembly P/N 437-0058,
right hand door P/N 437-0060 and necessary hardware.
- 005-0146 Dual Schedule Weld Power Kit for use on Cobramatic
'Champ' Wire Feeders Model #151-001 only.
Consists of: Dual Schedule Module P/N 003-0414,
switch P/N 159-0005, right hand handle P/N 437-0141
and switch hardware.

KING COBRA® TORCH BARREL ASSEMBLIES

STANDARD STRAIGHT BARREL

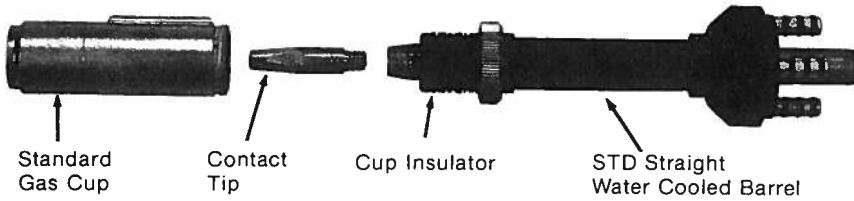

OPTIONAL HEAVY DUTY BARREL

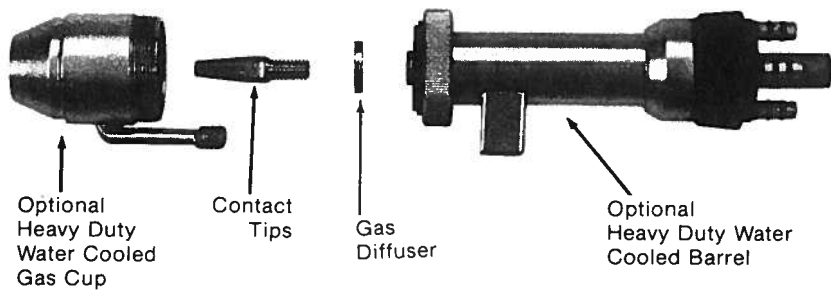

OPTIONAL CURVED BARREL

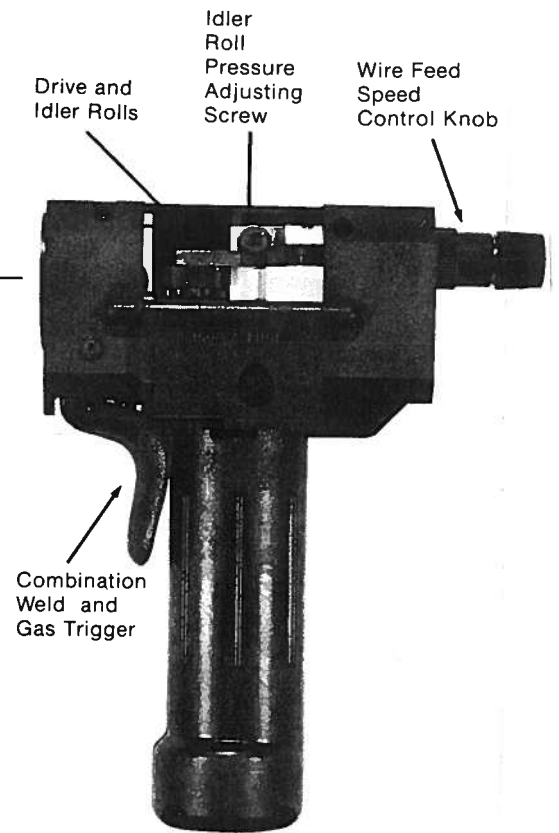
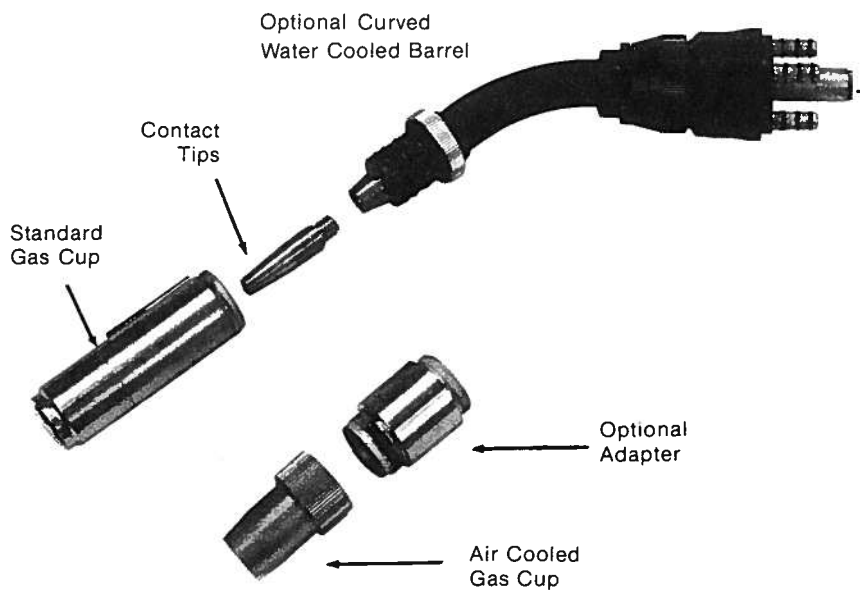

CUSTOM BARREL ASSEMBLIES

Both the straight and curved King Cobra Barrel Assemblies are now available in six, twelve, and eighteen inch lengths. All of the above barrel assemblies are available as replacement parts; or, may be installed on new King Cobra torches at the time the order is placed. If a requirement for a particular radius and angle is desired on the twelve or eighteen inch barrel assemblies, we will custom bend these barrels upon request. This has proven extremely successful in robotic applications where the radius and angle are critical. Custom barrel order forms are available upon request.

**KING COBRA® TORCH
BARREL ASSEMBLIES
(continued)**

STANDARD 6" STRAIGHT BARREL

P/N 001-1765



OPTIONAL 6" CURVED BARREL

P/N 001-1750



OPTIONAL 12" STRAIGHT BARREL

P/N 001-1766



OPTIONAL 12" CURVED BARREL

P/N 001-1751



OPTIONAL 18" STRAIGHT BARREL

P/N 001-1767



OPTIONAL 18" CURVED BARREL

P/N 001-1752



OPTIONAL 29" STRAIGHT BARREL

P/N 001-1768



The unique plug-in design of the King Cobra barrel assembly allows the operator to quickly change from one barrel assembly to another.

Any one of the above barrel assemblies may be installed on new King Cobra torches, if requested at the time the order is placed.

KING COBRA® TORCH

Dwg. No. 097-0007

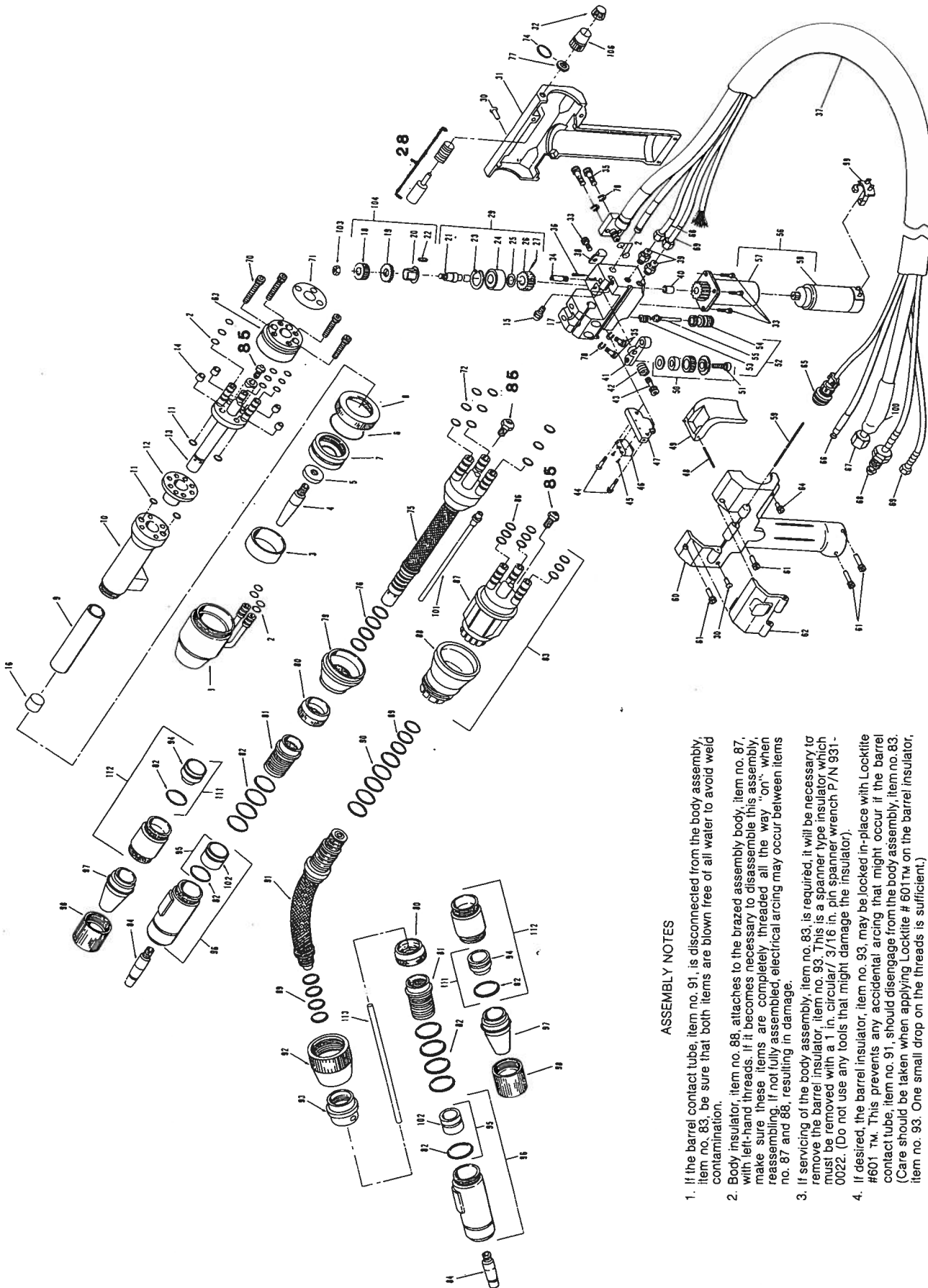

ASSEMBLY NOTES

1. If the barrel contact tube, item no. 91, is disconnected from the body assembly, item no. 83, be sure that both items are blown free of all water to avoid weld contamination.
2. Body insulator, item no. 88, attaches to the brazed assembly body, item no. 87, with left-hand threads. If it becomes necessary to disassemble this assembly, make sure these items are completely threaded all the way "on" when reassembling. If not fully assembled, electrical arcing may occur between items no. 87 and 88, resulting in damage.
3. If servicing of the body assembly, item no. 83, is required, it will be necessary to remove the barrel insulator, item no. 93. This is a spanner type insulator which must be removed with a 1 in. circular/3/16 in. pin spanner wrench P/N 931-0022. (Do not use any tools that might damage the insulator).
4. If desired, the barrel insulator, item no. 93, may be locked in-place with Locktite #601™. This prevents any accidental arcing that might occur if the barrel contact tube, item no. 91, should disengage from the body assembly, item no. 83. (Care should be taken when applying Locktite #601™ on the barrel insulator, item no. 93. One small drop on the threads is sufficient.)

PARTS LIST KING COBRA® TORCH

ITEM	PART NO.	QTY.	DESCRIPTION	ITEM	PART NO.	QTY.	DESCRIPTION
1	SEE PAGE 9	1	Cup Water/Cooled	65	See Page 16		Elec. Cable Assemblies
2	303-0081	15	'O' Ring BNA .176 I.D. x .05 THK. (Incl. w/ 1, 13, and 67)	66	615-0007	1	15' Conduit
3	261-0672	1	Insulator H.D. Gas Cup (Incl. w/ 1)		615-0008	1	25' Conduit
4	SEE PAGE 9	1	Contact Tip H.D. Barrel		615-0583	1	30' Conduit
5	SEE TABLE PAGE 15	1	Baffle		615-0068	1	50' Conduit
6	303-3189	1	'O' Ring BNA 1.176 I.D. x .070 THK.	67	843-0030	1	15' Power-Water Cable Assy.
7	431-0684	1	Adpt. Ring #12-16 W/C H.D. Barrel		843-0031	1	25' Power-Water Cable Assy.
8	431-0774	1	Knurled Nut #12-16 W/C H.D. Barrel		843-0032	1	30' Power-Water Cable Assy.
9	261-0063	1	Insulator Long H.D. Barrel		843-0029	1	50' Power-Water Cable Assy.
10	002-0139	1	Brazed Assy. #12-16 H.D. W/C Barrel	68	552-0001	1	15' Water In
11	303-0723	4	'O' Ring BNA .114 I.D. x .07 THK.		552-0002	1	25' Water In
12	261-0001	1	Insulator H.D. Barrel		552-0003	1	30' Water In
13	002-0111	1	Contact Tube H.D. Barrel		552-0040	1	50' Water In
14	342-0400	4	Sleeve Insulator	69	552-0004	1	15' Gas Hose
15	431-0888	2	Wire Guide Inlet		552-0005	1	25' Gas Hose
16	261-0255	1	Front Insulator H.D. Barrel		552-0006	1	30' Gas Hose
17	431-0158	1	Torch Body King	70	328-0028	4	Screw, 8-32 x 7/8 Soc. Hd. Cap.
18	431-0873	1	Knurled Drive Roll Housing (Incl. w/ 104)	71	261-0011	1	Insulator Disc
19	507-0211	1	Spur Gear	72	303-0081	9	'O' Ring BNA .176 I.D. x .05 THK. (Incl. w/ 75)
20	261-0242	1	Insulator Drive Roll (Incl. w/ 104)	74	303-0540	1	'O' Ring BNA .426 I.D. x .07 THK.
21	431-0132	1	Drive Roll Shaft (Incl. w/ 29)	75	003-0187	1	6" Barrel Contact Tube Assy.
22	421-0403	1	Phenolic Key (Incl. w/ 104)		003-0191	1	12" Barrel Contact Tube Assy.
23	313-0003	1	Retaining Ring (Incl. w/ 29)		003-0217	1	18" Barrel Contact Tube Assy.
24	501-0207	1	Drive Shaft Bearing (Incl. w/ 29)		003-0192	1	29" Barrel Contact Tube Assy.
25	331-0108	1	Fiat Wshr. .255 x .442 x .015 (Incl. w/ 29)	76	303-0010	4	'O' Ring BNA .489 I.D. x .629 THK. (Incl. w/ 75)
26	507-0002	1	Drive Gear (Incl. w/ 29)	77	449-0542	1	Nut
27	421-0129	1	Drive Gear Roll Pin (Incl. w/ 29)	78	333-0007	4	Lock Wshr. #10 (Incl. w/ 17)
28	003-0423	1	5 Turn Pot. Retainer	79	261-0057	1	Body Insulator
29	001-0114	1	Drive Shaft Assembly	80	431-0977	1	Gas Cup Retainer Nut
30	320-0005	2	Screw, 6-32 x 3/8 Soc. Button Hd.	81	261-0049	1	Barrel Insulator
31	437-0060	1	Right Side Handle	82	303-0012	6	'O' Ring BNA .676 I.D. x .816 THK. (Incl. w/ 81, 95 and 111)
32	401-0521	1	Knob	83	003-0247	1	Body Assembly
33	328-0012	5	Screw, 6-32 x 3/8 Soc. Hd. Cap.	84	SEE PAGE 1	1	Contact Tip Standard
34	431-0162	1	Idler Arm Pin	85	431-1067	1	Wire Guide Insulated
35	328-0047	4	Screw, 10-32 x 5/8 Soc. Hd. Cap. (Incl. w/ 17)	86	303-0081	9	'O' Ring BNA .176 I.D. x .05 THK. (Incl. w/ 87)
36	321-0421	1	Set Screw 6-32 x 3/4 Mod.	87	002-0269	1	Brazed Assembly Body (Incl. w/ 83)
37	551-0272	1	15' Cable Cover	88	261-0270	1	Body Insulator (Incl. w/ 83)
	551-0273	1	25' Cable Cover	89	303-0010	7	'O' Ring BNA .489 I.D. x .629 THK. (Incl. w/ 91)
	551-0292	1	30' Cable Cover	90	303-0011	5	'O' Ring BNA .614 I.D. x .754 THK. (Incl. w/ 91)
	551-0293	1	50' Cable Cover	91	003-0244	1	6" Barrel Contact Tube Assy.
38	411-0158	1	Cable Clamp		003-0245	1	12" Barrel Contact Tube Assy.
39	753-0114	2	Adapter Fitting		003-0246	1	18" Barrel Contact Tube Assy.
40	501-0004	1	Bearing	92	431-1089	1	Barrel Retaining Nut
41	431-0181	1	Idler Arm	93	261-0271	1	Spanner Barrel Insulator
42	419-0020	1	Idler Roll Pressure Adj. Spring	94	261-0234	1	Adapter Insulator (Incl. w/ 111)
43	431-0015	1	Idler Roll Pressure Adj. Screw	95	261-0240	1	Gas Cup Insulator Assy. (Incl. w/ 96)
44	325-0133	2	Screw, 6-32 x 3/8 Pn. Hd.	96	621-0065	1	#10 W/C Gas Cup Assy.
45	325-0025	2	Screw, 2-56 x 3/8 Pn. Hd.	97	SEE PAGE 8	1	Air Cooled Gas Cup Assy.
46	161-0002	1	Micro Switch	98	449-0193	1	Cup Retaining Nut
47	431-0032	1	Switch Mounting Bracket	99	921-0024	1	Motor Brushes (Replacement) (Incl. w/ 58)
48	421-0016	1	Trigger Pin	100	301-0097	2	Water/Power Cable Boot (Incl. w/ 67)
49	001-0116	1	Trigger	101	SEE PAGE 2	1	Barrel Liner
50	511-0087	1	Insulated Idler Roll Assembly	102	261-0239	1	Gas Cup Insulator (Incl. w/ 95)
51	320-0019	1	Btn Hd Scr. 10-24X3/8 (Incl. w/ 50)	103	350-0004	1	Insulated Drive Roll Retaining Nut
52	001-0562	1	Gas Valve Assembly	104	511-0064	1	Insulated Drive Roll Assy.
53	419-0742	1	Gas Valve Spring (Incl. w/ 52)	106	261-0247	1	Insulated Pot. Nut
** 54	001-0553	1	Gas Valve Seat Assy. (Incl. w/ 52) (Includes (2) 303-0518 'O' Rings)				
55	001-0740	1	Valve Stem Assy. (Incl. w/ 52) (Includes (2) 303-0723 'O' Rings)				
56	001-0101	1	Motor & Gear Box Assy. 700 I.P.M.				
	001-0641	1	Motor & Gear Box Assy. 1000 I.P.M.				
57	001-0153	1	Gear Box Assembly 700 I.P.M. (Incl. w/ 56 - 001-0101)				
	001-0645	1	Gear Box Assembly 1000 I.P.M. (Incl. w/ 56 - 001-0641)				
58	001-0155	1	Motor 24 Volt DC (Incl. w/ 58)				
* 59	421-0015	1	Door Pin	111	261-0235	1	Adapter Insulator Assy. (Incl. w/ 112)
60	437-0055	1	Left Side Handle	112	621-0101	1	Gas Cup Adapter Assy.
61	328-0014	4	Screw, 6-32 x 5/8 Soc. Hd. Cap.	113	See Page 2	1	Curved Barrel Liner
62	437-0057	1	Door				
63	431-0138	1	Barrel Insulator				
64	328-0016	1	Screw, 6-32 x 7/8 Soc. Hd. Cap.				

* 437-0058 - Left hand handle & door assembly

- 15 -

**NOTE: Feeders equipped with gas solenoid require valve stem P/N 431-1080 in torch.

KING COBRA ELECTRICAL CABLE ASSEMBLIES
(Item #65, page 15)

King Cobra Torch Model Prefix Nos. 118 & 133
(7 Pin Amphenol Connectors)

Length	Part Number
3	001-0958
6	001-0959
10	001-0960
15	001-0610
25	001-0611
30	001-0612
50	001-0664

King Cobra Torch Model Prefix Nos. 141 & 142
(10 Pin Amphenol Connectors)

Length	Part Number
3	843-0204
6	843-0205
10	843-0206
15	843-0196
25	843-0197
30	843-0198
50	843-0199

Special Torch Lead Assemblies

	3 ft	6 ft	10 ft
	<u>P/N 001-1006</u>	<u>P/N 001-1007</u>	<u>P/N 001-1008</u>
Conduit (Poly Lined)	615-0077	615-0657	615-0006
Coolant Hose	552-0050	552-0026	552-0055
Gas Hose	552-0049	552-0025	552-0056
Wtr/Pwr Cable	843-0071	843-0082	843-0081
Electrical Cable	See Above		
Lead Ass'y. Cover	551-0269	551-0270	551-0217

AIR COOLED CURVED BARRELS

48 DEGREE P/N 001-1807

45 DEGREE P/N 001-1788

ITEM	PART NO.	QUAN.	DESCRIPTION
1	003-0436	1	S/A Body
2	431-1067	Ref.	Wire Guide
3	003-0385	1	Barrel Mount Assy.
4	449-0195	1	Cup Retaining Nut
5	313-0018	Ref.	Retaining Ring 3/4 Dia.
6	431-1187	Ref.	Collet Tip
7	621-0217	1	#10 Cup, 48°
8	See Pg. #10	1	Liner
9	See Pg. #10	1	Contact Tip

ITEM	PART NO.	QUAN.	DESCRIPTION
1	003-0436	1	S/A Body
2	431-1067	Ref.	Wire Guide
3	003-0385	1	Barrel Mount Assy.
4	449-0195	1	Cup Retaining Nut
5	313-0018	Ref.	Retaining Ring 3/4 Dia
6	431-1187	Ref.	Collet Tip
7	621-0102	1	#10 Cup - 45°
8	See Pg. #10	1	Liner
9	See Pg. #10	1	Contact Tip

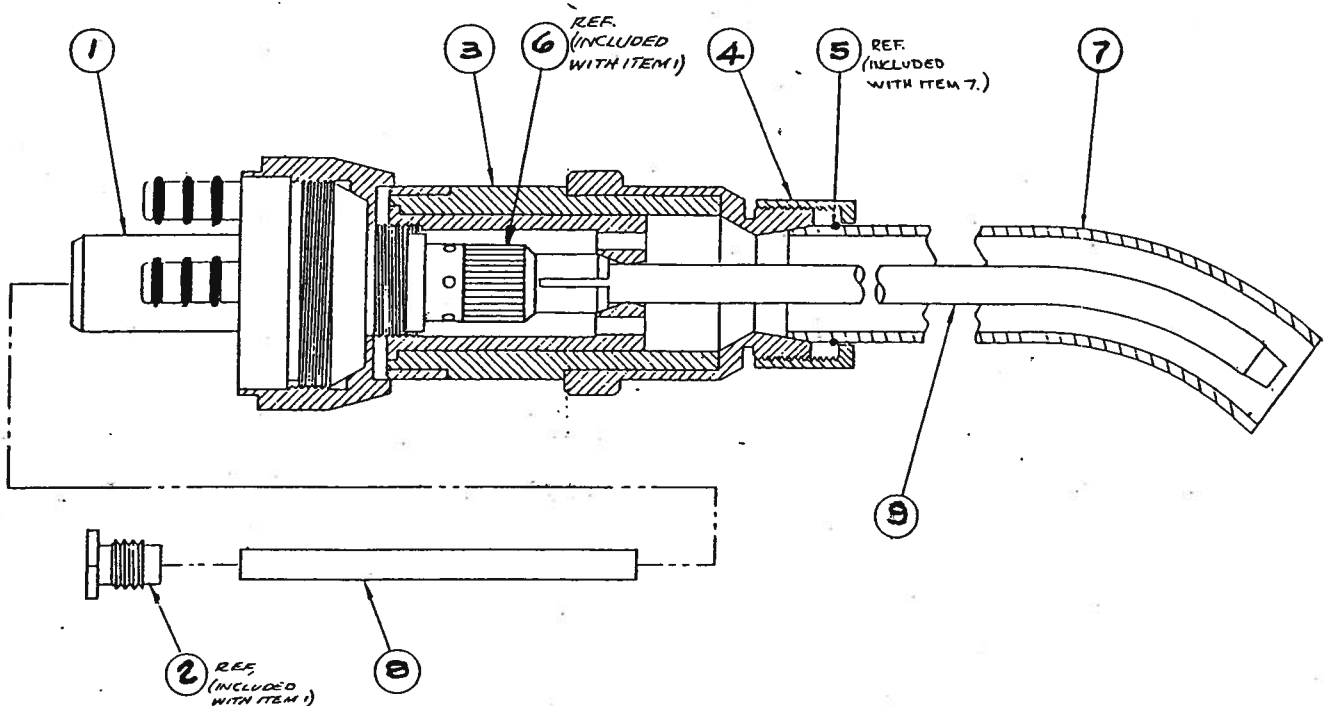

AIR COOLED STRAIGHT BARREL

P/N 001-1880 PARTS LIST

ITEM	PART NO.	QUAN.	DESCRIPTION
1	003-0436	1	S/A Body
2	431-1067	Ref.	Wire Guide
3	003-0385	1	Barrel Mount Assy.
4	449-0195	1	Cup Retaining Nut
5	313-0018	Ref.	Retaining Ring 3/4 Dia.
6	621-0216	1	Straight Cup
7	See Pg. #9	1	Liner
8	See Pg. #9	1	Contact Tip
9	431-1187	1	Collet Tip

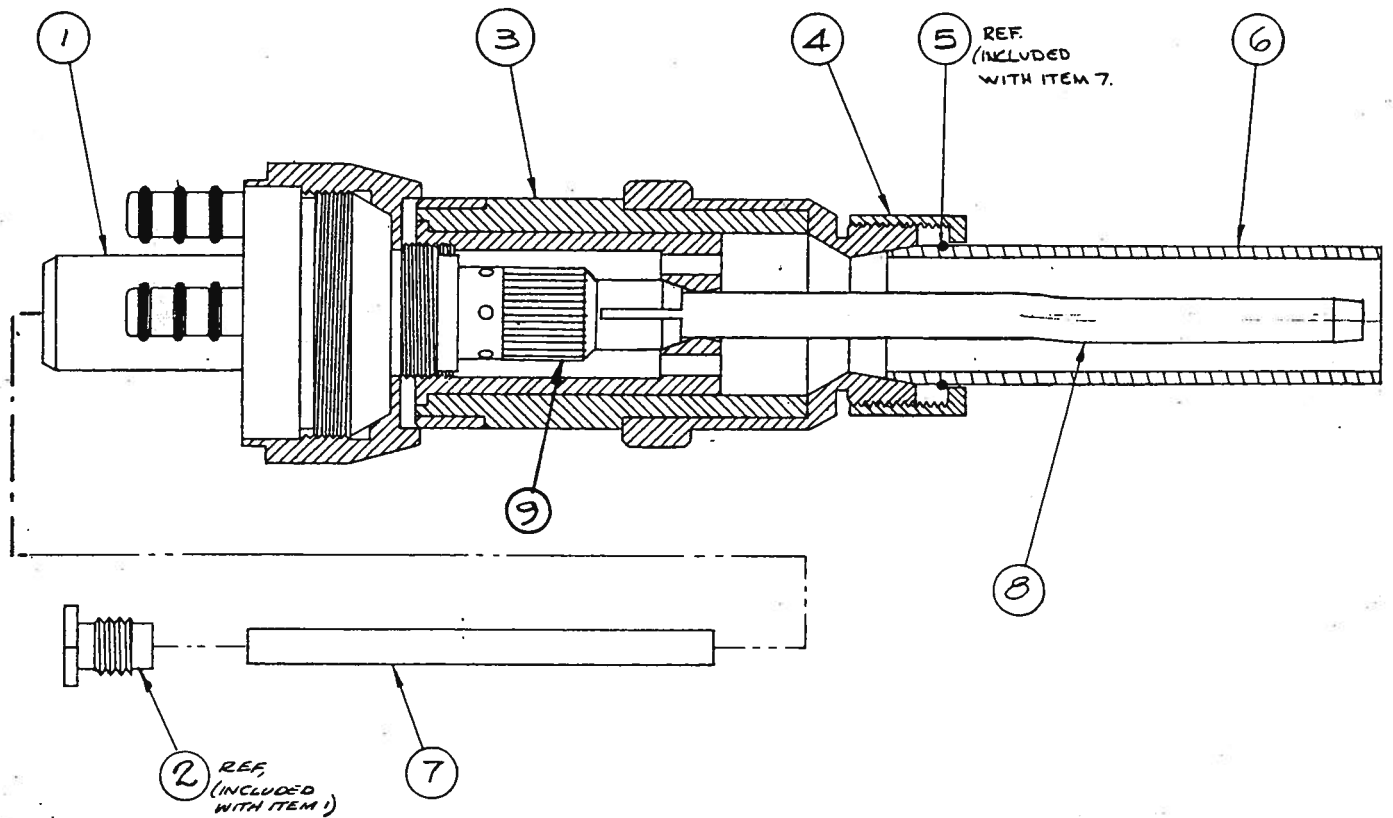

HEAVY DUTY KING COBRA - 500 IPM

Model No. Prefix 143 & 144.



Item 24., GEAR BOX ASS'Y.
Includes Items: 27,28,33,34.

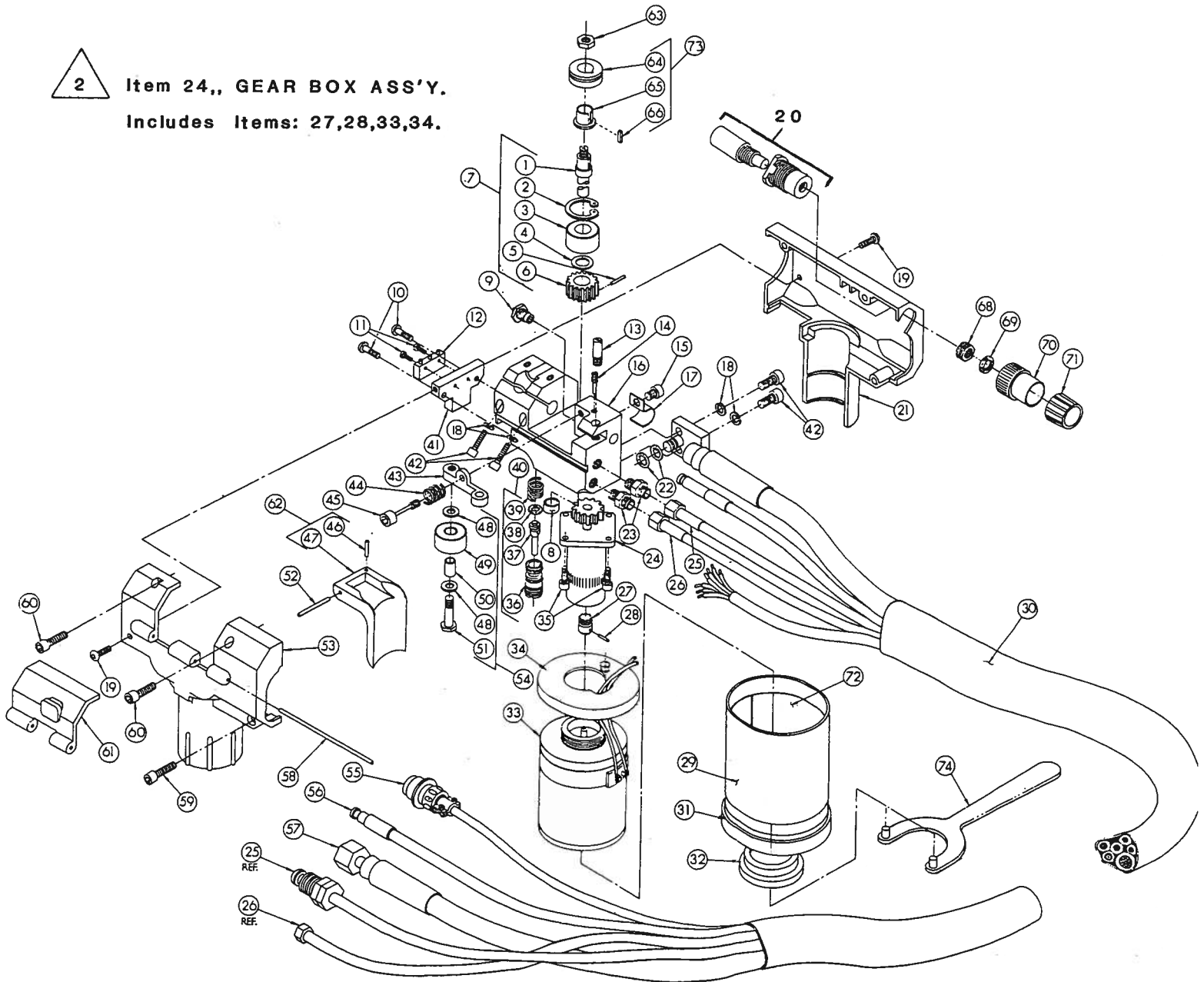

ITEM	P/N	DESCRIPTION
35	328-0012	4 SCREW, S.H.D. 6-32 x 3/8
32	431-1154	1 HANDLE RETAINER
31	431-1139	1 HANDLE CAP
29	431-1141	1 HANDLE (TUBE)
24	003-0379	1 GEAR BOX, 500 I.P.M., H.D.M.T.
23	753-0014	2 ADAPTER FITTING
21	437-0135	1 R. SIDE HANDLE
20	003-0423	1 POT/RETAINER
19	320-0005	2 SCREW, S.O.U.T.H.D., 6-32 x 3/8
18	333-0007	4 LOCK WASHER, #10
17	411-0158	1 CABLE CLAMP
16	431-0158	1 TORCH BODY, KING
15	328-0012	1 SCREW, S.H.D. 6-32 x 3/8
14	321-0421	1 SET SCREW, MOD. 6-32 x 1/2
13	431-0162	1 IDLER ARM PIN
12	161-0002	1 MICRO SWITCH
11	325-0025	2 SCREW, R.H.D. 2-56 x 3/8
10	325-0133	2 SCREW, R.H.D. 6-32 x 3/8
9	CUSTOMER SPECIF.	REF. INSUL. WIRE GUIDE
8	501-0004	1 BEARING
7	001-0114	1 ASSY, DRIVE SHAFT

ITEM	P/N	DESCRIPTION
74	921-0132	1 SPANNER WRENCH
73	CUSTOMER SPEC. REF.	DRIVE ROLL ASSY
72	261-0385	1 HANDLE INSULATOR
71	401-0521	1 KNOB
70	261-0247	1 INSUL. POT NUT
69	303-0540	1 O-RING, BUNA, .176 I.D. x .05
68	449-0542	1 NUT
67		1
63	350-0004	1 NUT, INSUL. DR. ROLL RET.
62	431-1158	1 TRIGGER, MODIF.
60	328-0014	1 SCREW, S.H.D. 6-32 x 5/8
59	328-0016	1 SCREW, S.H.D. 6-32 x 7/8
54	511-0071	1 INSUL. IDLER ROLL
53	437-0134	1 L. SIDE HANDLE ASSY
52	421-0016	1 TRIGGER PIN
45	431-0015	1 IDLER ROLL PRESS. ADJ. SCR.
44	419-0053	1 IDLER ROLL PRESS. ADJ. SPRING
43	431-0161	1 IDLER ARM
42	328-0047	4 SCREW, S.H.D. 10-32 x 5/8
41	431-0032	1 BRACKET, SWITCH MTE.
40	001-0562	1 ASSY, GAS VALVE

NOTE: Feeders equipped with gas solenoid require valve stem P/N 431-1080 in torch.

500 I.P.M. HEAVY-DUTY KING COBRA TORCH
DRIVE ROLL INSTALLATION INSTRUCTIONS

NOTE: Refer to Dwg. 097-0049 Torch Exploded View & Parts List, page 19, for items numbers listed below.

Tools Required: Allen Wrench Set, 2 ea. Small Slot Type Screwdrivers, 3/8" Open End Wrench, Spanner Wrench, MK P/N 921-0132

Parts Replaced: Existing Drive & Idler Rolls

INSTALLATION:

1. Disconnect torch electrical cable from wire feeder.
 2. Remove trigger pin, item 52.
 3. Torch handle tube (stainless) item 29 and bottom cap, item 31, are held in compression to upper handle section by handle retainer, item 32, which threads onto motor, item 33, by means of spanner wrench, item 74. NOTE: Alignment pin on item 34 locates on notch in R.H. Handle, item 21.
 4. Loosen handle retainer, item 32 (approximately 3 turns). Note: Unthreading handle retainer completely is not necessary. Rotation of spacer, item 34, can cause damage to torch wires.
 5. Depending on type of drive rolls in existing King Cobra Torch, proceed as follows:
 - (A) Knurled Drive & Idler Rolls Removal
 1. Restrain gear under drive roll, and remove self-locking nut above drive roll.
 2. Using two (2) screwdrivers, pry drive roll & drive gear from drive shaft.
 - (B) Grooved Drive Roll Removal
 1. Restrain existing drive roll by inserting 1/16" Allen wrench into hole located on drive roll just below groove, and remove nut above drive roll.
 2. Using two (2) screwdrivers, pry drive roll from drive shaft.
 7. Install Idler Roll Assembly as shown, item 54.
 8. Taking care to clear Micro Switch actuator arm, fit right-hand handle in place
 9. Fit left handle in place and reassemble handle screws.
 10. Orient spacer, item 34, handle tube, item 29, and handle cap, item 31, as shown BEFORE tightening handle retainer, item 32.
 11. Reassemble Trigger.
- CAUTION: If lower handle parts are removed completely, handle insulator, item 72, MUST BE installed to provide proper weld power insulation of tube, item 29, to motor, item 33.
12. Installation Complete

WIRING SCHEMATIC

Dwg. No. 071-0135
 (CONTROL CABINET MK3A 001-0517 & MK3APS 001-0519)
 Model No. Prefix 150

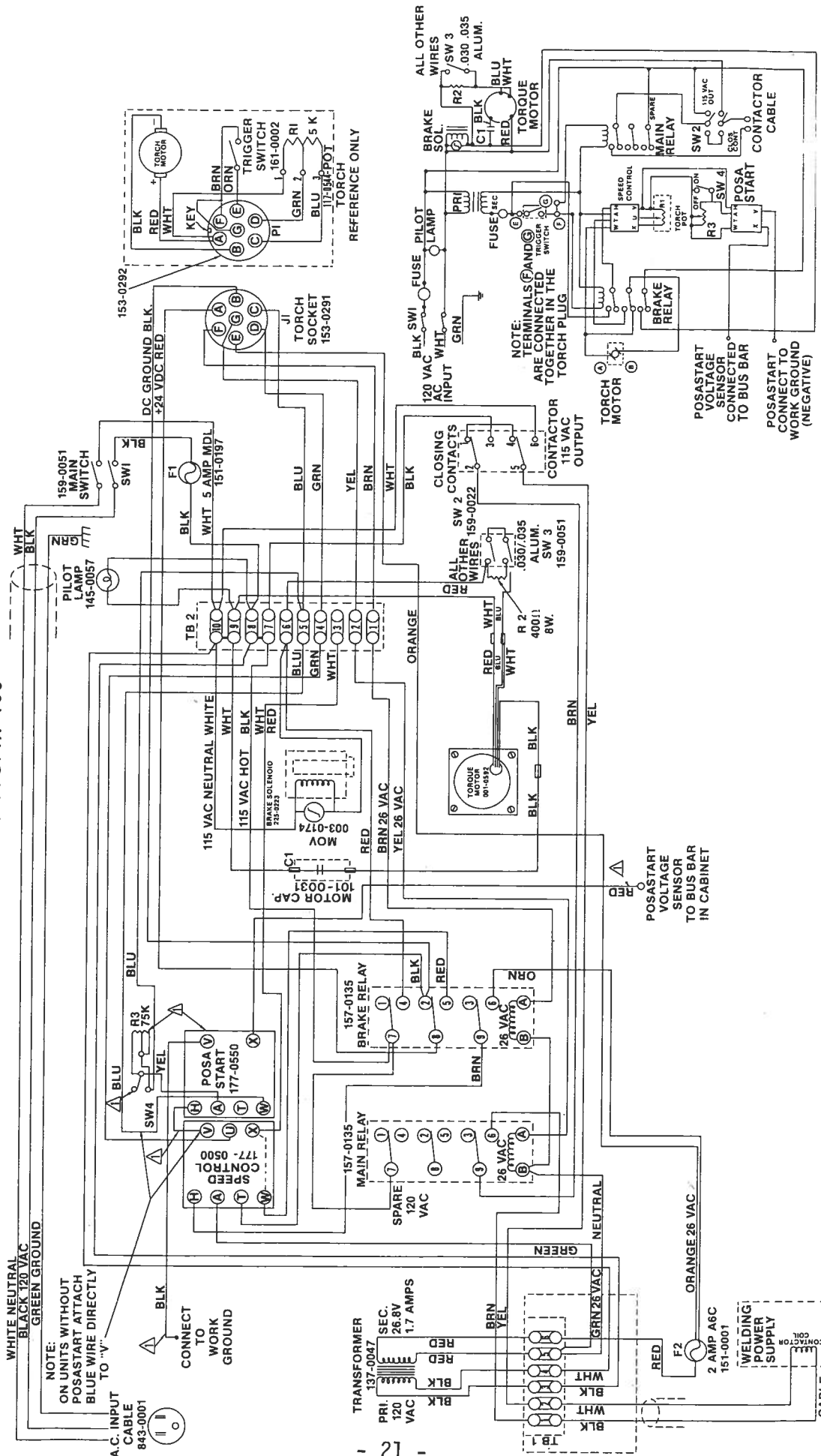

NOTE: Δ POSASTART UNITS ONLY

REVISIONS			
LTR	DESCRIPTION	BY	APPROV DATE
-	REL/PROD DCN 4533	SM	11/17 7/61
A	ADDED WIRE BUNDLE DELI 4616	SM	11/17 7/61
B	DCN 4657	SM	11/17 7/61
C	DCN 4711	SM	11/17 7/61

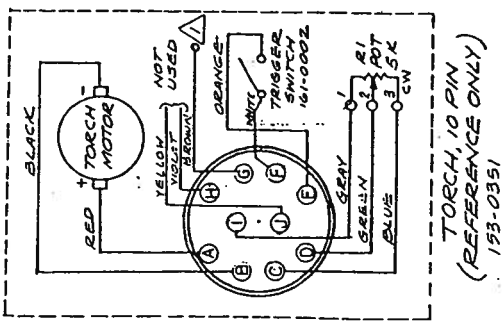
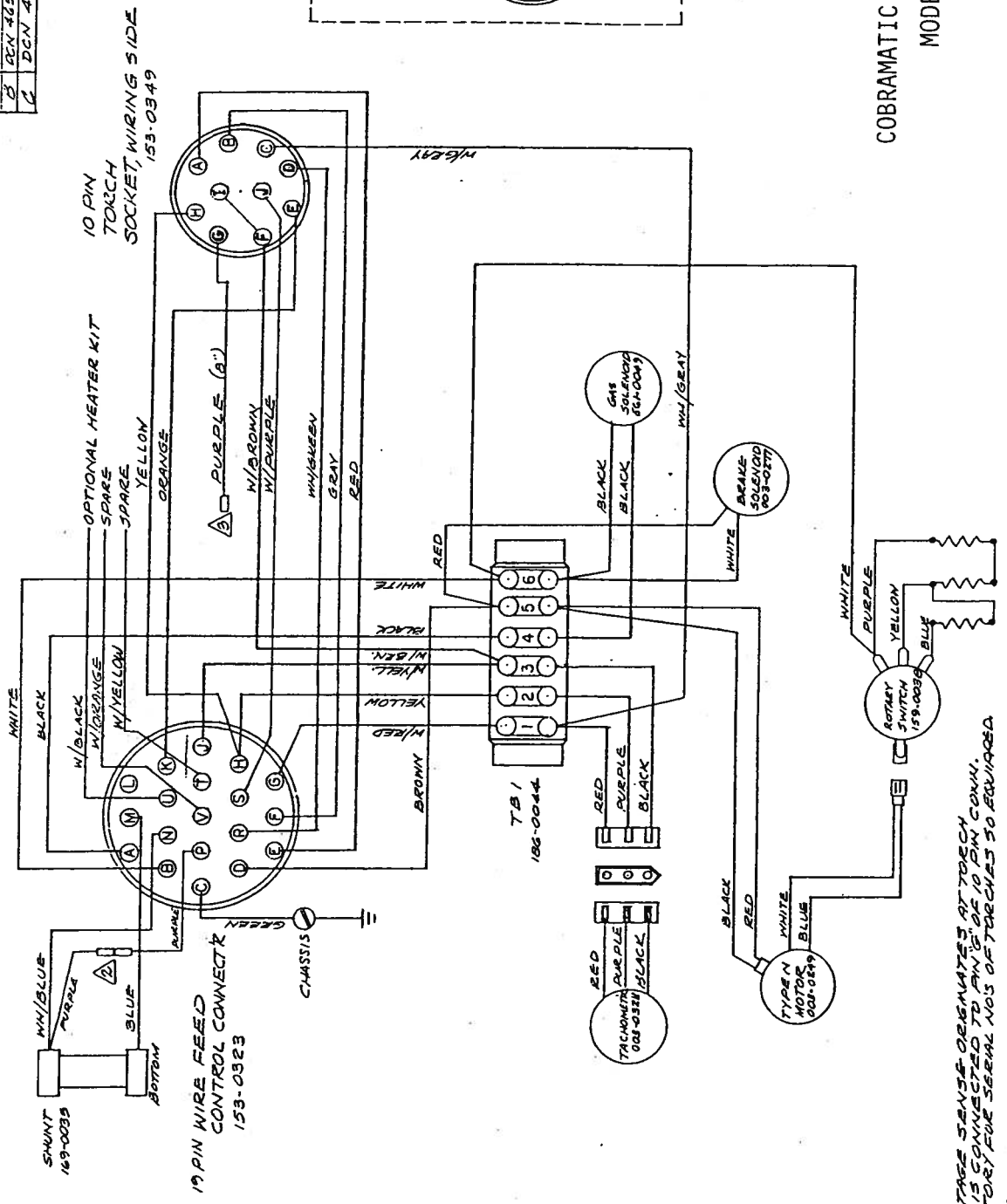

COBRAMATIC CHAMP WIRE FEEDER
MODEL 151-001

- △ OPTIONAL VOLTAGE SENSE ORIGINATES AT TORCH WHEN PIN 'D' IS CONNECTED TO PIN 'O' OF 19 PIN CONN. CONSULT FACTORY FOR SERIAL NOS OF TORCHES SO EQUIPPED.
- △ WHEN PURPLE WIRE FROM SHUNT IS CONNECTED AS SHOWN TO PIN 'D' OF 19 PIN CONNECTOR, VOLTAGE SENSE ORIGINATES AT SHUNT.
- △ BROWN WIRE, PIN 'G', ATTACHES TO KING TORCH BLOCK, SECURE WIRE UNDER ELEC. CABLE CLAMP.

NOTES

ITEM	MATERIAL or PART NO.	REQ.	SPECIFICATION or DESCRIPTION
1	153-0349	1	10 PIN TORCH SOCKET, WIRING SIDE
2	153-0351	1	TORCH, 10 PIN (REFERENCE ONLY)
3	159-0036	1	ROTARY SWITCH
4	003-0277	1	BRAKE SOLENOID
5	008-0328	1	TACHOMETER
6	68-0043	1	GAS SOLENOID
7	169-0039	1	SHUNT
8	153-0323	1	19 PIN WIRE FEED CONTROL CONNECTOR
9	182-0044	1	TERMINAL BLOCK
10	001-0249	1	TYPE N MOTOR

UNLESS OTHERWISE SPECIFIED ALL DIMENSIONS ARE IN INCHES
TOL - DEC. XX ± .010 XXX ± .005 ANGLES ± .5°
DIMENSIONS TO BE SQUARE WITHIN .003 IN.
BREAK SHARP EDGES .010 MAX. WITHIN .005 TH
FILLETS .005 R. MAX. - MACH. SURF. FINISH ✓

DATE	BY	APPROV
09/01/72		

USED ON
NEXT ASSY

11.1.11
MK PRODUCTS, INC. 071-0199
MILWAUKEE, WIS. U.S.A.

COBRAMATIC BRUTE WIRE FEEDER
MODEL 151-002

CONNECTOR DESIGNATIONS

DRWG. No. 033-0150

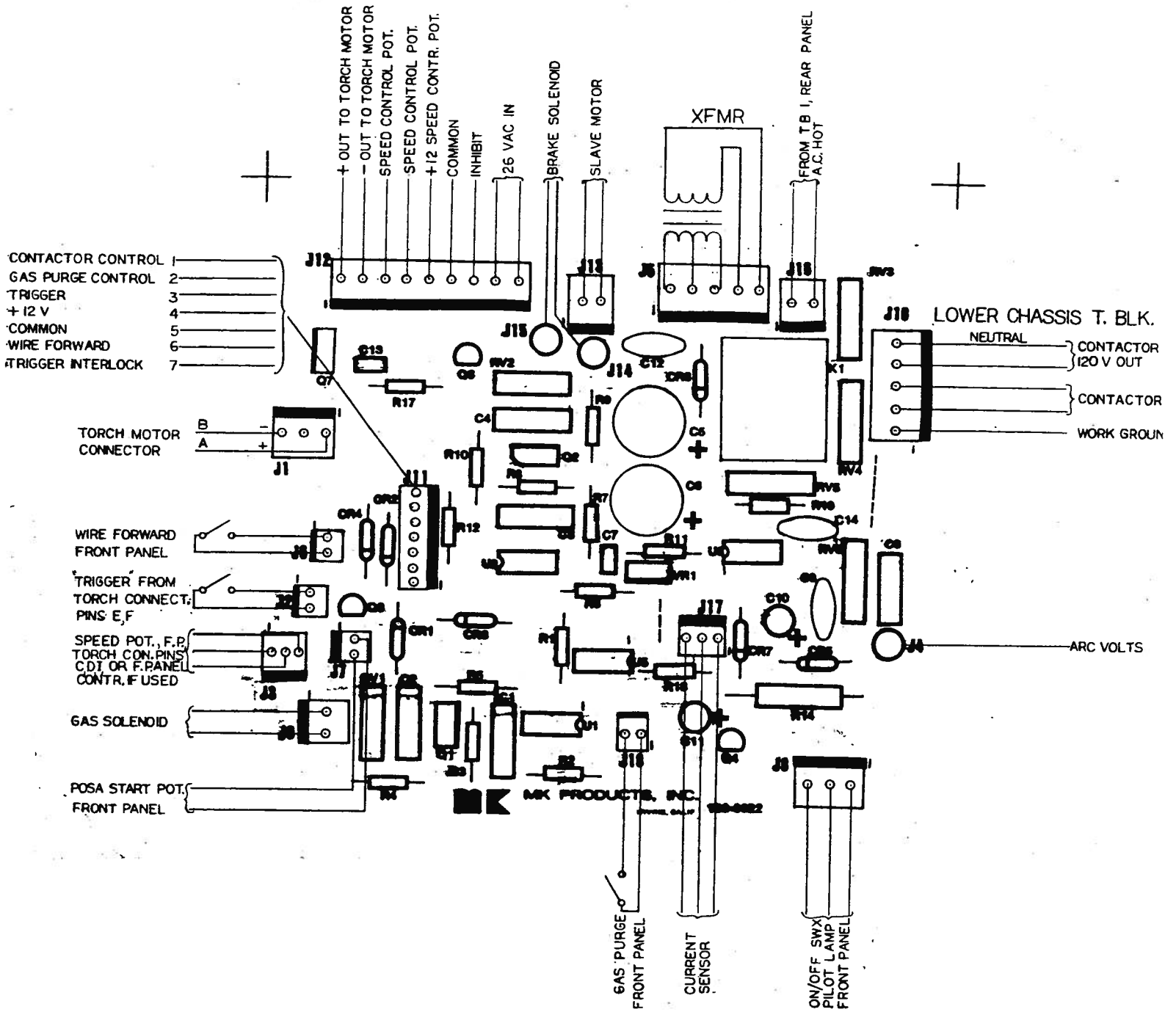



LIMITED WARRANTY EFFECTIVE AUGUST 1978

This warranty supercedes all previous M.K. PRODUCTS warranties and is exclusive with no other guarantees or warranties expressed or implied.

LIMITED WARRANTY — M. K. Products, Inc., Irvine, California warrants to customer that all new and unused equipment furnished by M.K. Products is free from defect in workmanship and material as of the time and place of delivery by M.K. Products. No warranty is made by M.K. Products with respect to trade accessories or other items manufactured by others. Such trade accessories and other items are sold subject to the warranties of their respective manufacturers, if any.

M.K. Products warranty does not apply to components having normal useful life of less than one (1) year, such as relay points, wire conduit and welding torch parts that come in contact with the welding wire including nozzles, nozzle insulators and contact tips where failure does not result from defect in workmanship or material.

In the case of M.K. Products' breach of warranty or any other duty with respect to the quality of any goods, the exclusive remedies therefor shall be at M.K. Products' option, (1) repair or (2) replacement or (3) where authorized in writing by M.K. Products the reasonable cost of repair or replacement at our Irvine, Calif. plant or (4) payment of or credit for the purchase price (less reasonable depreciation based upon actual use) upon return of the goods at customer's risk and expense. Upon receipt of notice of apparent defect or failure, M.K. Products shall instruct the claimant on the warranty claim procedures to be followed.

As a matter of general policy only, M.K. Products may honor an original user's warranty claims on warranted equipment in the event of failure resulting from a defect within ninety (90) days from the date of delivery of Equipment to the original user.

A copy of the distributor's invoice to the end user, showing the date of sale, must accompany products returned for warranty repair or replacement.

Normal surface transportation charges (both ways) for products returned for warranty repair or replacement will be borne by M.K. Products. Except for products sold for foreign markets.

ANY EXPRESS WARRANTY NOT PROVIDED HEREIN AND ANY IMPLIED WARRANTY, GUARANTY OR REPRESENTATION AS TO PERFORMANCE, AND ANY REMEDY FOR BREACH OF CONTRACT WHICH, BUT FOR THIS PROVISION, MIGHT ARISE BY IMPLICATION, OPERATION OF LAW, CUSTOM OF TRADE OR COURSE OF DEALING, INCLUDING ANY IMPLIED WARRANTY OF MERCHANTABILITY OR OF FITNESS FOR PARTICULAR PURPOSE, WITH RESPECT TO ANY AND ALL EQUIPMENT FURNISHED BY M.K. PRODUCTS IS EXCLUDED AND DISCLAIMED BY M. K. PRODUCTS.

EXCEPT AS EXPRESSLY PROVIDED BY M. K. PRODUCTS IN WRITING, M.K. PRODUCTS ARE INTENDED FOR ULTIMATE PURCHASE BY COMMERCIAL/INDUSTRIAL USERS AND FOR OPERATION BY PERSONS TRAINED AND EXPERIENCED IN THE USE AND MAINTENANCE OF WELDING EQUIPMENT AND NOT, FOR CONSUMERS OR CONSUMER USE, M.K. PRODUCTS WARRANTIES DO NOT EXTEND TO, AND NO RESELLER IS AUTHORIZED TO EXTEND M.K. PRODUCTS' WARRANTIES TO, ANY CONSUMER.



THIS PAGE INTENTIONALLY BLANK

We're Big On **MIG**®

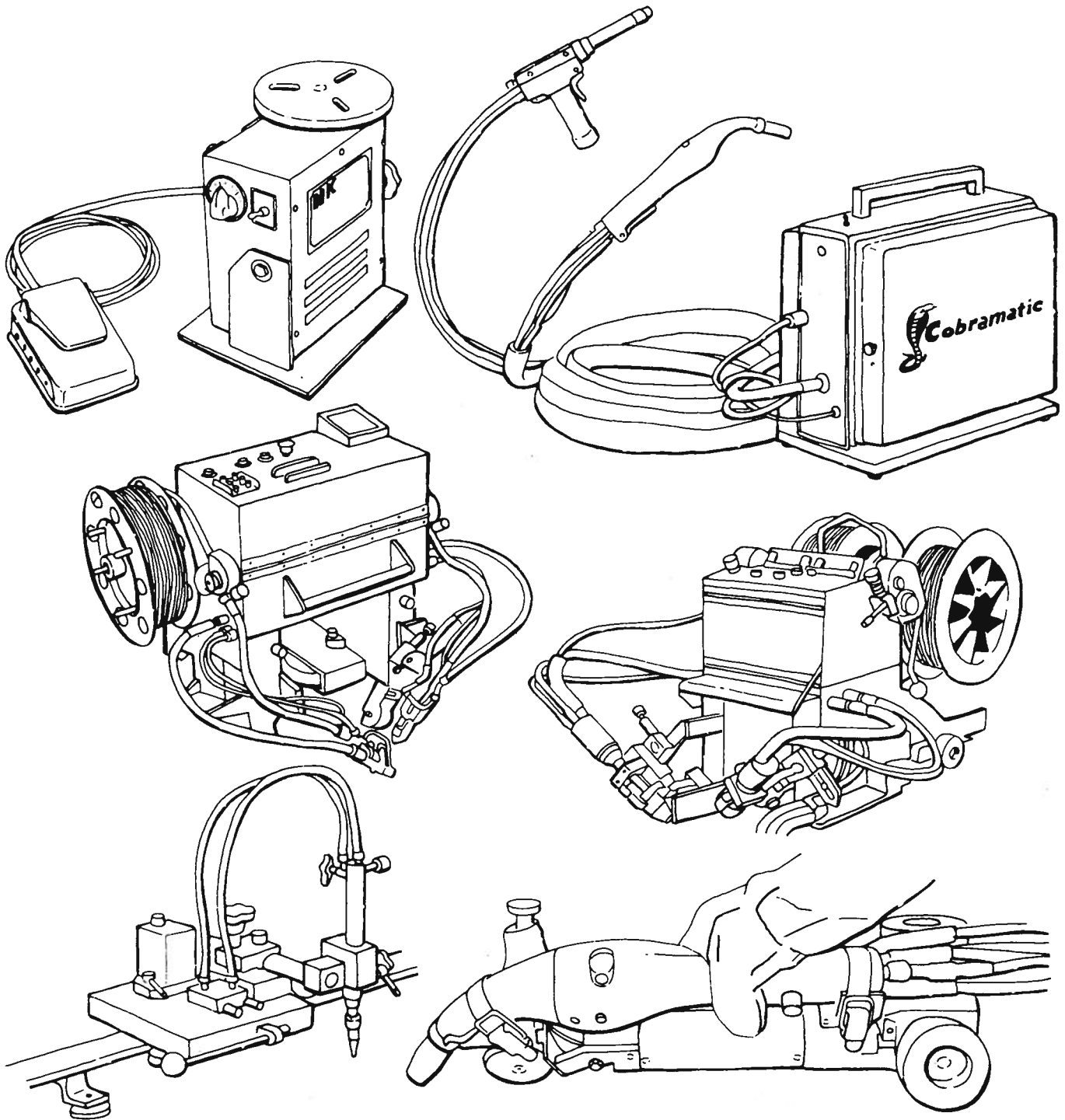

M.K. PRODUCTS, INC.
16882 ARMSTRONG AVE. • IRVINE, CALIFORNIA 92714 • (714) 863-1234 • TELEX 692369