



CobraTig® 150 SM Owner's Manual

Product:	CobraTig®
Manual:	091-0675
Serial:	13110001
Voltage Rating:	100/120/208- 220/230-240VAC
Revision:	Nov 2013 Rev B
Model Number:	254-153 254-252



Table of Contents

INTRODUCTION	1
Section 1 Technical Information.....	2
Section 2 Mechanical Information	2
Section 3 Weldhead and Torches	2
Section 4 Connections	3
Section 5 Operation	5
Section 6 Main Menu	6
Section 7 Weld Manual	6
Section 8 Weld Orbital	8
Section 9 Recall Program	9
Section 10 Save Program.....	10
Section 11 Auto Program Generator.....	11
Section 12 Print Menu	12
Section 13 Calibration Menu.....	14
Section 14 Communication Menu.....	16
Section 15 Setup Menu.....	17
Section 17 Diagnostic Menu	18

Declaration of Conformity for European Community (CE) Products

Note  This information is provided for units with CE certification (see rating label on unit).

Manufacturer's Name: **MK Products, Inc.**
16882 Armstrong Ave.
Irvine, CA 92606

Declares that the product: **CobraTig® 150 SM**
conforms to the following Directives and Standards:

Directives

Low Voltage Directive: 2006/95/EC

Electromagnetic Compatibility (EMC) Directive: 2004/108/EC

Standards

Electromagnetic Compatibility, (EMC): EN 60974-10: 2007

Torches And Guns For Arc Welding, EN 60974-7: 2005

SAFETY CONSIDERATIONS

ELECTRIC ARC WELDING EQUIPMENT

CAUTION : READ BEFORE ATTEMPTING INSTALLATION, OPERATION OR MAINTENANCE OF THIS EQUIPMENT

1-1 INTRODUCTION

This equipment is intended for ultimate application by commercial/industrial users and for operation by persons trained and experienced in the use and maintenance of welding equipment. Operation should not be undertaken without adequate training in the use of such equipment. Training is available from many public and private schools or similar facilities.

Safe practices in the installation, operation and maintenance of this equipment requires proper training in the art, a careful study of the information provided with the equipment, and the use of common sense. Rules for safe use are generally provided by suppliers of welding power sources, compressed gas suppliers, and electrode suppliers. Careful compliance with these rules will promote safe use of this equipment.

The following Safety Rules cover some of the more generally found situations. READ THEM CAREFULLY. In case of any doubt, obtain qualified help before proceeding.

1-2 GENERAL PRECAUTIONS

A. Burn Prevention

ELECTRIC ARC WELDING PRODUCES HIGH INTENSITY HEAT AND ULTRAVIOLET RADIANT ENERGY WHICH MAY CAUSE SERIOUS AND PERMANENT EYE DAMAGE AND WHICH MAY DAMAGE ANY EXPOSED SKIN AREAS.

Wear helmet with safety goggles or glasses with side shields underneath, appropriate filter lenses or plates (protected by clear cover glass). This is a must for welding or cutting (and chipping) to protect the eyes from radiant energy and flying metal. Replace cover glass when broken, pitted, or spattered.

Medical first aid and eye treatment. First aid facilities and a qualified first aid person should be available for each shift unless medical facilities are close by for immediate treatment of flash burns of the eyes and skin burns.

Wear protective clothing - leather (or asbestos) gauntlet gloves, hat, and high safety-toe shoes. Button shirt collar and pocket flaps, and wear cuffless trousers to avoid entry of sparks and slag.

Avoid oily or greasy clothing. A spark may ignite them.

Flammable hair preparations should not be used by persons intending to weld or cut.

Hot metal such as electrode stubs and work pieces should never be handled without gloves.

Ear plugs should be worn when working on overhead or in a confined space. A hard hat should be worn when others work overhead.

B. Toxic Fume Prevention

WARNING: The use of this product may result in exposure to chemicals known to the State of California to cause cancer and birth defects or other reproductive harm.

Adequate ventilation. Severe discomfort, illness or death can result from fumes, vapors, heat, or oxygen enrichment or depletion that welding (or cutting) may produce. Prevent them with adequate ventilation. NEVER ventilate with oxygen.

Lead-, cadmium-, zinc-, mercury-, beryllium-bearing and similar materials, when welded or cut, may produce harmful concentrations of toxic fumes. Adequate local exhaust ventilation must be used, or each person in the area, as well as the operator, must wear an air-supplied respirator. For beryllium, both must be used.

Metals coated with or containing materials that emit toxic fumes should not be heated unless coating is removed from the work surface, the area is well ventilated, or the operator wears an air-supplied respirator.

Work in a confined space only while it is being ventilated and, if necessary, while wearing an air-supplied respirator.

Gas leaks in a confined space should be avoided. Leaked gas in large quantities can change oxygen concentration dangerously. Do not bring gas cylinders into a confined space.

Leaving confined space, shut OFF gas supply at source to prevent possible accumulation of gases in the space if downstream valves have been accidentally opened or left open. Check to be sure that the space is safe before reentering it.

Vapors from chlorinated solvents can be decomposed by the heat of the arc (or flame) to form PHOSGENE, a highly toxic gas, and other lung and eye irritating products. The ultraviolet (radiant) energy of the arc can also decompose trichloroethylene and perchloroethylene vapors to form phosgene. DO NOT WELD or cut where solvent vapors can be drawn into the welding or cutting atmosphere or where the radiant energy can penetrate to atmospheres containing even minute amounts of trichloroethylene or perchloroethylene.

C. Fire and Explosion Prevention

Causes of fire and explosion are: combus-

tibles reached by the arc, flame, flying sparks, hot slag, or heated material, misuse of compressed gases and cylinders, and short circuits.

BE AWARE THAT flying sparks or falling slag can pass through cracks, along pipes, through windows or doors, and through wall or floor openings, out of sight of the goggled operator. Sparks can fly many feet.

To prevent fires and explosion:

Keep equipment clean and operable, free of oil, grease, and (in electrical parts) of metallic particles that can cause short circuits.

If combustibles are in area, do NOT weld or cut. Move the work if practicable, to an area free of combustibles. Avoid paint spray rooms, dip tanks, storage areas, ventilators. If the work cannot be moved, move combustibles at least 35 feet away, out of reach of sparks and heat; or protect against ignition with suitable and snug-fitting, fire-resistant covers or shields.

Walls touching combustibles on opposite sides should not be welded on (or cut). Walls, ceilings, and floor near work should be protected by heat-resistant covers or shields.

Fire watcher must be standing by with suitable fire extinguishing equipment during and for some time after welding or cutting if:

1. Appreciable combustibles (including building construction) are within 35 feet.
2. Appreciable combustibles are further than 35 feet, but can be ignited by sparks.
3. Openings (concealed or visible) in floors or walls within 35 feet may expose combustibles to sparks.
4. Combustibles adjacent to walls, ceilings, roofs, or metal partitions can be ignited by radiant or conducted heat.

Hot work permit should be obtained before operation to ensure supervisor's approval that adequate precautions have been taken.

After work is done, check that area is free of sparks, glowing embers, and flames.

An empty container that held combustibles, or that can produce flammable or toxic vapors when heated, must never be welded on or cut, unless container has first been cleaned in accordance with industry standards.

This includes: a thorough steam or caustic cleaning (or a solvent of water

washing, depending on the combustible's solubility), followed by purging and inerting with nitrogen or carbon dioxide, and using protective equipment.

Water-filling just below working level may substitute for inerting.

A container with unknown contents should be cleaned (see paragraph above). Do NOT depend on sense of smell or sight to determine if it is safe to weld or cut.

Hollow castings or containers must be vented before welding or cutting. They can explode.

Explosive atmospheres. NEVER weld or cut where the air may contain flammable dust, gas, or liquid vapors (such as gasoline).

D. Compressed Gas Equipment

The safe handling of compressed gas equipment is detailed in numerous industry publications. The following general rules cover many of the most common situations.

1. Pressure Regulators

Regulator relief valve is designed to protect only the regulator from overpressure; it is not intended to protect any downstream equipment. Provide such protection with one or more relief devices.

Never connect a regulator to a cylinder containing gas other than that for which the regulator was designed.

Remove faulty regulator from service immediately for repair (first close cylinder valve). The following symptoms indicate a faulty regulator:

Leaks - if gas leaks externally.

Excessive Creep - if delivery pressure continues to rise with downstream valve closed.

Faulty Gauge - if gauge pointer does not move off stop pin when pressurized, nor returns to stop pin after pressure release.

Repair. Do NOT attempt repair. Send faulty regulators for repair to manufacturer's designated repair center, where special techniques and tools are used by trained personnel.

2. Cylinders

Cylinders must be handled carefully to prevent leaks and damage to their walls, valves, or safety devices:

Avoid electrical circuit contact with cylinders including third rails, electrical wires, or welding circuits. They can produce short circuit arcs that may lead to a serious accident. (See 1-3C)

ICC or DOT marking must be on each cylinder. It is an assurance of safety when the cylinder is properly handled.

Identifying gas content. Use only cylinders with name of gas marked on them; do not rely on color to identify gas content. Notify supplier if unmarked. NEVER DEFACE or alter name, number, or other markings on a cylinder. It is illegal and

hazardous.

Empties: Keep valves closed, replace caps securely; mark MT; keep them separate from FULLS, and return promptly.

Prohibited use. Never use a cylinder or its contents for other than its intended use, NEVER as a support or roller.

Locate or secure cylinders so they cannot be knocked over.

Passageways and work areas. Keep cylinders clear of areas where they may be stuck.

Transporting cylinders. With a crane, use a secure support such as a platform or cradle. Do NOT lift cylinders off the ground by their valves or caps, or by chains, slings, or magnets.

Do NOT expose cylinders to excessive heat, sparks, slag, and flame, etc. that may cause rupture. Do not allow contents to exceed 55 degrees C (130 degrees F.) Cool with water spray where such exposure exists.

Protect cylinders, particularly valves from bumps, falls, falling objects, and weather. Replace caps securely when moving cylinders.

Stuck valve. Do NOT use a hammer or wrench to open a cylinder valve that cannot be opened by hand. Notify your supplier.

Mixing gases. NEVER try to mix any gases in a cylinder.

NEVER refill any cylinder.

Cylinder fittings should never be modified or exchanged.

3. Hose

Prohibited use. Never use hose other than that designed for the specified gas. A general hose identification rule is: red for fuel gas, green for oxygen, and black for inert gases.

Use ferrules or clamps designed for the hose (not ordinary wire or other substitute) as a binding to connect hoses to fittings.

No copper tubing splices. Use only standard brass fittings to splice hose.

Avoid long runs to prevent kinks and abuse. Suspend hose off ground to keep it from being run over, stepped on, or otherwise damaged.

Coil excess hose to prevent kinks and tangles.

Protect hose from damage by sharp edges, and by sparks, slag, and open flame.

Examine hose regularly for leaks, wear, and loose connections. Immerse pressured hose in water; bubbles indicate leaks

Repair leaky or worn hose by cutting area out and splicing. Do NOT use tape.

4. Proper Connections

Clean cylinder valve outlet of impurities that may clog orifices and damage seats before connecting regulator. Except for hydrogen, crack valve momentarily, pointing outlet away from people and sources of ignition. Wipe with a clean, lintless cloth.

Match regulator to cylinder. Before connecting, check that the regulator label and

cylinder marking agree, and that the regulator inlet and cylinder outlet match. NEVER Connect a regulator designed for a particular gas or gases to a cylinder containing any other gas.

Tighten connections. When assembling threaded connections, clean and smooth seats where necessary. Tighten. If connection leaks, disassemble, clean, and retighten, using properly fitting wrench.

Adapters. Use a CGA adapter (available from your supplier) between cylinder and regulator, if one is required. Use two wrenches to tighten adapter marked RIGHT and LEFT HAND threads.

Regulator outlet (or hose) connections may be identified by right hand threads for oxygen and left hand threads (with grooved hex on nut or shank) for fuel gas.

5. Pressurizing Steps:

Drain regulator of residual gas through suitable vent before opening cylinder (or manifold valve) by turning adjusting screw in (clockwise). Draining prevents excessive compression heat at high pressure seat by allowing seat to open on pressurization. Leave adjusting screw engaged slightly on single-stage regulators.

Stand to side of regulator while opening cylinder valve.

Open cylinder valve slowly so that regulator pressure increases slowly. When gauge is pressurized (gauge reaches regulator maximum) leave cylinder valve in following position: for oxygen and inert gases, open fully to seal stem against possible leak; for fuel gas, open to less than one turn to permit quick emergency shut-off.

Use pressure charts (available from your supplier) for safe and efficient recommended pressure settings on regulators.

Check for leaks on first pressurization and regularly thereafter. Brush with soap solution. Bubbles indicate leaks. Clean off soapy water after test; dried soap is combustible.

E. User Responsibilities

Follow all Safety Rules.

Remove leaky or defective equipment from service immediately for repair. Read and follow user manual instructions.

F. Leaving Equipment Unattended

Close gas supply at source and drain gas.

G. Rope Staging-Support

Rope staging-support should not be used for welding or cutting operation; rope may burn.

1-3 ARC WELDING

Comply with precautions in 1-1, 1-2, and this section. Arc Welding, properly done, is a safe process, but a careless

operator invites trouble. The equipment carries high currents at significant voltages. The arc is very bright and hot. Sparks fly, fumes rise, ultraviolet and infrared energy radiates, weldments are hot, and compressed gases may be used. The wise operator avoids unnecessary risks and protects himself and others from accidents.

A. Burn Protection

Comply with precautions in 1-2.

The welding arc is intense and visibly bright. Its radiation can damage eyes, penetrate lightweight clothing, reflect from light-colored surfaces, and burn the skin and eyes. Skin burns resemble acute sunburn; those from gas-shielded arcs are more severe and painful. **DON'T GET BURNED; COMPLY WITH PRECAUTIONS.**

1. Protective Clothing

Wear long-sleeve clothing in addition to gloves, hat, and shoes. As necessary, use additional protective clothing such as leather jacket or sleeves, flameproof apron, and fire-resistant leggings. Avoid outer garments of untreated cotton.

Bare skin protection. Wear dark, substantial clothing. Button collar to protect chest and neck, and button pockets to prevent entry of sparks.

2. Eye and Head Protection

Protect eyes from exposure to arc. Eyes may be damaged by radiant energy when exposed to the electric arc, even when not looking in the direction of the arc. Never look at an electric arc without protection.

Welding helmet or shield containing a filter plate shade no. 12 or denser must be used when welding. Place over face before striking arc.

Protect filter plate with a clear cover plate.

Cracked or broken helmet or shield should NOT be worn; radiation can be passed through to cause burns.

Cracked, broken, or loose filter plates must be replaced IMMEDIATELY. Replace clear cover plate when broken, pitted, or spattered.

Flash goggles with side shields MUST be worn under the helmet to give some protection to the eyes should the helmet not be lowered over the face before an arc is struck. Looking at an arc momentarily with unprotected eyes (particularly a high intensity gas-shielded arc) can cause a retinal burn that may leave a permanent dark area in the field of vision.

3. Protection of Nearby Personnel

Enclose the welding area. For production welding, a separate room or enclosed bay is best. In open areas, surround the operation with low-reflective, noncombustible screens or panels. Allow for free air circulation, particularly at floor level.

Viewing the weld. Provide face shields for all persons who will be looking directly

at the weld.

Others working in area. See that all persons are wearing flash goggles.

Before starting to weld, make sure that screen flaps or bay doors are closed.

B. Toxic Fume Prevention

Comply with precautions in 1-2B.

Generator engine exhaust must be vented to the outside air. Carbon monoxide can kill.

C. Fire and Explosion Prevention

Comply with precautions in 1-2C.

Equipment's rated capacity. Do not overload arc welding equipment. It may overheat cables and cause a fire.

Loose cable connections may overheat or flash and cause afire.

Never strike an arc on a cylinder or other pressure vessel. It creates a brittle area that can cause a violent rupture or lead to such a rupture later under rough handling.

D. Compressed Gas Equipment

Comply with precautions in 1-2D.

E. Shock Prevention

Exposed electrically hot conductors or other bare metal in the welding circuit, or in ungrounded, electrically-HOT

equipment can fatally shock a person whose body becomes a conductor. **DO NOT STAND, SIT, LIE, LEAN ON, OR TOUCH** a wet surface when welding without suitable protection.

To protect against shock:

Keep body and clothing dry. Never work in damp area without adequate insulation against electrical shock. Stay on a dry duckboard, or rubber mat when dampness or sweat cannot be avoided. Sweat, sea water, or moisture between body and an electrically HOT part - or grounded metal - reduces the body surface electrical resistance, enabling dangerous and possibly lethal currents to flow through the body.

1. Grounding the Equipment

When installing, connect the frames of each unit such as welding power source, control, work table, and water circulator to the building ground. Conductors must be adequate to carry ground currents safely. Equipment made electrically HOT by stray currents may shock, possibly fatally. Do NOT GROUND to electrical conduit, or to a pipe carrying ANY gas or a flammable liquid such as oil or fuel.

Three-phase connection. Check phase requirement of equipment before installing. If only three-phase power is available, connect single-phase equipment to only two wires of the three-phase line. Do NOT connect the equipment ground lead to the third (live) wire, or the equipment will become electrically HOT - a dangerous condition that can shock, possibly fatally.

Before welding, check ground for continuity. Be sure conductors are touching bare metal of equipment frames at connections.

If a line cord with a ground lead is provided with the equipment for connection to a

switch box, connect the ground lead to the grounded switch box. If a three-prong plug is added for connection to a grounded mating receptacle, the ground lead must be connected to the ground prong only. If the line cord comes with a three-prong plug, connect to a grounded mating receptacle. Never remove the ground prong from a plug, or use a plug with a broken ground prong.

2. Connectors

Fully insulated lock-type connectors should be used to join welding cable lengths.

3. Cables

Frequently inspect cables for wear, cracks, and damage. IMMEDIATELY REPLACE those with excessively worn or damaged insulation to avoid possibly lethal shock from bared cable. Cables with damaged areas may be taped to give resistance equivalent to original cable.

Keep cable dry, free of oil and grease, and protected from hot metal and sparks.

4. Terminals and Other Exposed Parts

Terminals and other exposed parts of electrical units should have insulating covers secured before operation.

5. Electrode Wire

Electrode wire becomes electrically HOT when the power switch of gas metal-arc welding equipment is ON and welding gun trigger is pressed. Keep hands and body clear of wire and other HOT parts.

6. Safety Devices

Safety devices such as interlocks and circuit breakers should not be disconnected or shunted out.

Before installation, inspection, or service of equipment, shut OFF all power, and remove line fuses (or lock or red-tag switches) to prevent accidental turning ON of power. Disconnect all cables from welding power source, and pull all 115 volts line-cord plugs.

Do not open power circuit or change polarity while welding. If, in an emergency, it must be disconnected, guard against shock burns or flash from switch arcing.

Leaving equipment unattended. Always shut OFF, and disconnect all power to equipment.

Power disconnect switch must be available near the welding power source.

Thank You

For selecting a quality product. We want you to take pride in operating this product...as much pride as we have in bringing the product to you!

Please Examine Carton and Equipment For Damage Immediately

When this equipment is shipped, title passes to the purchaser upon receipt by the carrier. Consequently, claims for material damaged in shipment must be made by the purchaser against the transportation company at the time the shipment is received.

Please record your equipment identification information below for future reference. This information can be found on your machine nameplate.

Model Name & Number _____

Code & Serial Number _____

Date of Purchase _____

Whenever you request replacements parts for, or information on this equipment always supply the information you have recorded above.

Read this Owner's Manual completely before attempting to use this equipment. Save this manual and keep it handy for quick reference. Pay particular attention to the safety instructions we have provided for your protection.

INTRODUCTION

The portable, lightweight CobraTig 150 SM with SmartArc® provides the automatic control you need to deliver repeatability, verification and traceability in high-integrity orbital and manual welding.

SmartArc software develops a near ideal weld procedure through the use of our Automatic Procedure Generator. Just enter the tube outside diameter and wall thickness... The rest is automatic.

This version of CobraTig Software and Hardware has the latest in Micro-Tig Technology. The system is now capable of going down to 0.1 amps. High Voltage Pulse automatic arc starting from 0.5 to 25 amps.

Make the most of your offsite and onsite welding operations. With the CobraTig 150 SM, you'll weld circles around the competition.

Section 1

Technical Information

Line Power: 100VAC 50/60 Hz Single Phase, 15A
(+/- 10%) 120VAC 50/60 Hz Single Phase, 15A
208-220/230-240VAC 50/60 Hz Single or Three Phase, 30A

Output Current: 0.1~150A (+/- 1%), Constant or Pulsed

Minimum Arc Starting: 0.5 to 25 Amps

Pulse Rate: 0.01 to 2.25 Seconds Per Pulse

Arc Voltage: 65VDC Open Circuit, up to 26 welding VDC

Loop Response: 1.5 KHz

Current Regulator Freq: 30 KHz

Motor Control: 24VDC, 2A min., DC Tachometer Feedback.

Memory Storage: 25 Weld Procedures

Section 2

Mechanical Information

Weight: 42 lbs / 19.1 Kg
Height: 14 in. / 35.6 cm
Width: 8.5 in. / 21.6 cm
Length: 19 in. / 48.3 cm

Section 3

Weldhead and Torches

For robust solutions for orbital weld applications, the CopperHeads® are ideal cost savers for sanitary and high-pressure tube systems.

The CopperHead series are our most cost effective and rugged in-place orbital weldheads offered in three models. The CopperHead models 5001 (1/8 - 1 inch OD), 5002 (1/4 - 2 inch OD) and 5003 (1/2 - 3 inch OD) each offer versatility and high-output production rates.

The water-cooled, narrow profile CopperHeads are lightweight and easy to handle for those awkward welds with limited access.

All MK weldheads can be utilized as bench mounted or remotely controlled units.

The models and the capacities are as follows:



MODEL	CAPACITY (Max. OD)
5001	1/8" - 1"
5002	1/4" - 2"
5003	1/2" - 3"
5006	2" OD - 6" OD Tube

With a simple power connector pigtail (**P/N 005-0619**), all previously sold MK Orbital weldheads will adapt to the CobraTig 150 SM. You must change the previous electrode and ground cable connectors from the push-in type to a twist-lock type.

The order numbers for the twist-lock type are: **P/N 153-0755** Electrode (male connector to exchange for the black connector) and **P/N 153-0813** Ground (female connector to exchange for the green connector).

For MicroTig welding operations, the MicroTig Accessory Kit (P/N 005-0670) is also available. This contains all the necessary items needed when using the CobraTig 150 SM unit in the WELD MANUAL mode.

Precision MicroTig Technology is a standard feature of the CobraTig150 SM. The ideal precision manual welder produces reliable, smooth arc starts at 0.5 amps and is perfect for welding precision thin wall exotic materials such as titanium and stainless steel or fine wire sizes.

Section 4

Connections

Input Power

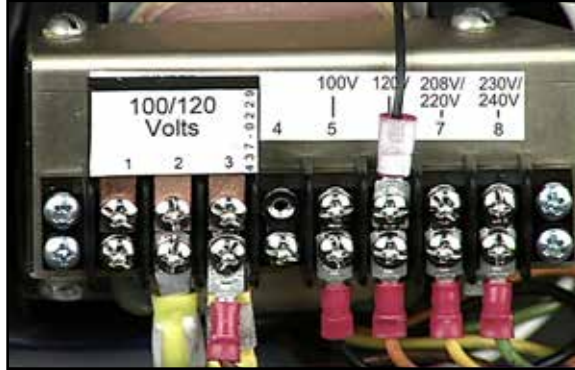

The CobraTig 150 SM can operate on any of four different input power values: 100VAC, 120VAC, 208-220/230-240VAC Single Phase and, 208-220/230-240VAC Three Phase. Attached to the unit is a 12ft power cable that comes wired from the factory ready for 120VAC. Even though the installed plug is only three prongs, there are four wires in the cable, ready for three phase power.

DANGER

DISCONNECT ALL POWER TO THE UNIT PRIOR TO CHANGING THE POWER TAPS. FAILURE TO DO THIS WILL RESULT IN SERIOUS BODILY HARM AND EXTENSIVE EQUIPMENT DAMAGE.

To change the input power type, three changes have to be made to the CobraTig 150 SM unit: first change the voltage jumper, then the voltage selector cable and the plug on the end of the cable. You will need a 1/4" nutdriver wrench and a #2 Phillips head screwdriver.

Using the nutdriver, remove all the 1/4" hex head screws from the cover of the unit, then lift the cover off. Locate TB1 on the lower-right-rear side of the unit, from the front. Using the Phillips head screwdriver to change the taps, follow the directions below:

Configure Voltage Selector Jumper at TB1 terminals 1-3, for the input voltage, 100V/120V or 208V-220/230-240VAC. Remove and flip over to change (see Jumper Configuration image).

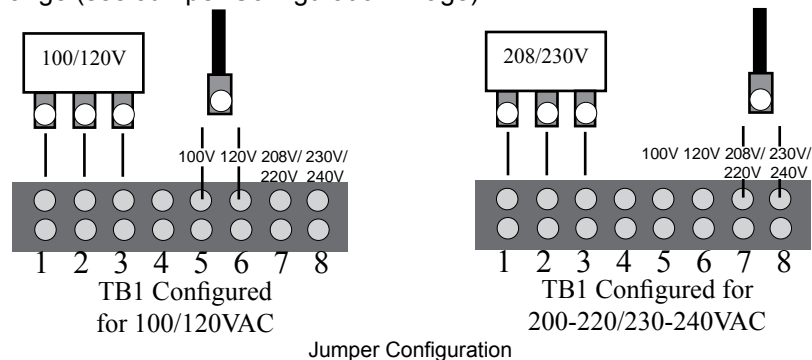

Move "Voltage Selector Cable" to the corresponding input voltage terminal of TB1 for 100V, 120V, 208V-220/230-240V.

After the input voltage taps have been configured, then change the plug on the end of the power cable to match.

SmartArc® Software Update

When viewing the MAIN MENU of the CobraTig 150 SM, the currently loaded software version will appear across the middle of the screen. Once the software update is properly performed, this version number will show the newly loaded version number.



In order to update the firmware version in the CobraTig® 150, the following items are needed:

- CobraTig 150.
- PC/Laptop running Windows (Mac not supported).
- Null Modem Cable (Female DB9 to Female DB9) and/or Serial to USB Adapter Cable
- MK Edit/SmartArc Weld Program Editor and latest CobraTig Firmware, downloaded and saved to the Desktop.

1. Connect the Null Modem to CobraTig rear panel and to PC/laptop serial port. A USB to Serial Port Adapter Cable is required if a serial port does not exist on the PC/laptop.
2. Once cabling is connected, on the CobraTig front panel, press and hold the F10 button (lower-right hand button) while powering on the CobraTig.

The screen will display “READY TO RECEIVE...”, as shown. If it does not, turn CobraTig off, wait 15 seconds and try again.



3. Run MK Edit. On the Tool Bar, select Send then select Send Firmware Upgrade to CobraTig (Ctrl + U).

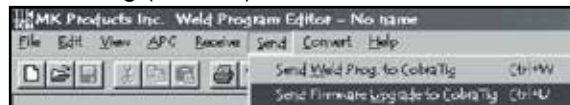

Choose the correct COM port, in accordance with your PC/laptop, from the CobraTig Communication dialog box. Press Start.

If the program returns with a COM Error Dialog Box indicating an invalid storage control block address, choose the other COM port from the CobraTig Communication Dialog box.*



From the Select Welder Upgrade dialog box, find the .150 files saved on the Desktop. Choose and highlight (or double-click) the file which begins upload to CobraTig.

4. Once the firmware upgrading starts, the screen on the CobraTig will show the status of the downloading. The bottom of this screen will count upwards the number of ‘blocks’ being received from MK Edit. Simultaneously, the CobraTig Communication Dialog box will show a bar graph, moving from left to right, as the firmware is being sent to the CobraTig.
5. Once the firmware has been successfully transmitted, restart the CobraTig (turn off, wait 15 seconds, then turn on) and disconnect Null

Section 5

Modem serial cable. View the CobraTig 150 MAIN MENU and inspect for the new firmware version number.

6. Installation Complete

OPERATION

To operate the CobraTig 150 SM portable orbital welding unit, plug in any standard MK Orbital weldhead to the rear panel, and perform the basic setup procedures associated with collets, tungsten, and concentricity. Plug the CobraTig 150 SM into any 120VAC electrical outlet (independent and isolated circuits will produce the best results), connect the quick disconnect gas fitting into the unit, and the other end to any argon flowmeter.

Power the unit on by rocking the ON/OFF switch to the ON position (located on the rear panel - see below). The unit will remember the last screen that was on when it was powered off. To start from the beginning, it is best to calibrate the weldhead prior to starting. Once the weldhead is calibrated, press any button that will return the screen to the MAIN MENU.

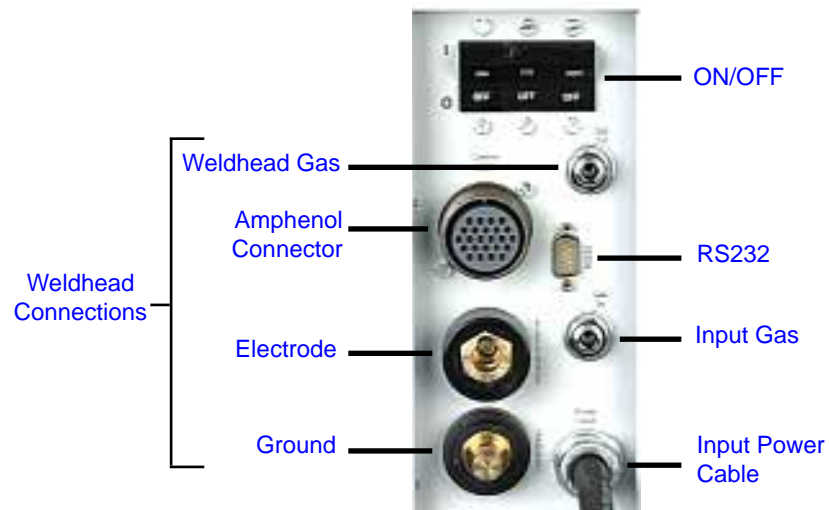

From this point use the AUTO PROG button to start designing the weld procedure, enter the appropriate variables for the material to be welded, prepare and align material to be welded, check for proper purge gas flow... Press START.

The CobraTig 150 SM unit will automatically prepurge the gas flow, initiate the welding arc, perform any tacks if so desired, complete the weld in one or multiple revolutions depending on procedure design and return the rotor to home position while the postpurge gas is flowing. Weld complete.

Weldhead Connector

CobraTig150 Connector Pin-outs

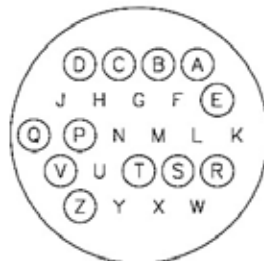

Male Plug
Back of Unit

- A DARK BROWN (MOTHOM)
- B GREEN (MOTHMR)
- C BLACK (MOTR)
- D RED (FNLSLP)
- E ORANGE (NXTLVL)
- P WHITE (MOTH)
- Q LIGHT BROWN (TACR)
- R PINK (TACH)
- S YELLOW (JOG)
- T BLUE (ST/STP)
- V PURPLE (SEQLED-)
- Z GRAY (SEQLED+)

Section 6

RS-232 Data Connector

The CobraTig uses a DB-9 connector to communicate with an External PC. The wiring for this plug is “cable/null” modem wiring (female connector both ends).

Main Menu

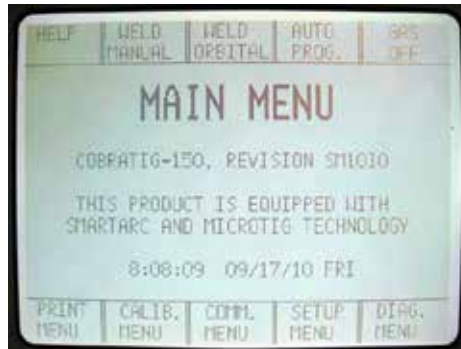

This is the starting menu for the CobraTig 150 SM orbital welder. It is from this menu that all the other menu displays and screens are accessible. From each menu display, there is a one-step button back to this menu.

This is not to say that every time this unit is turned on that it will start at this screen. The operating program is such that it will remember the last screen when the unit is turned off. When the unit is turned on again, it will start with the last screen displayed.

Help

Press this button to read a brief description of the MAIN MENU button descriptions and functions.

Section 7

Weld Manual

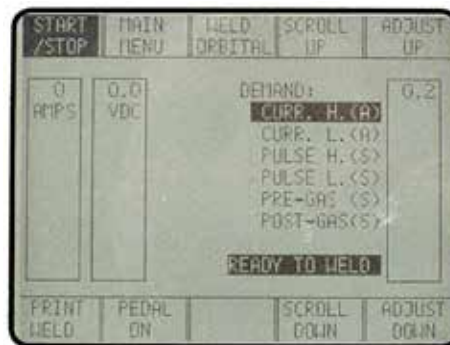

From the MAIN MENU screen, the WELD MANUAL button must be pressed in order to access the WELD MANUAL screen.

User Interface Programming Sequence

- From the Main Menu.
- Press F2 Weld Manual, permits manual welding.
- Press F7 and enter Pedal On, permits use of foot control for weld current Upslope and Final slope control and continuous welding.
- Press F7 and enter Pedal Off, permits use of ON/OFF switch with programmable weld current upslope and final slope times from 0.00~1.0 seconds each.
- Press F4 or F9 and scroll to Curr. H. (A), high weld current in amps.

Note: The Current High Amps establishes the maximum output in amps that may be obtained.

- Press F5 or F10 and enter High current value from 0.2~150 amps.

- Press F4 or F9 and scroll to Curr. L. (A), low weld current in amps.
- Press F5 or F10 and enter Low current value from 0.2~150 amps.
- Press F4 or F9 and scroll to Pulse H. (S), high weld current pulse time.
- Press F5 or F10 and enter High weld current pulse time from 0.00~0.99 seconds.
- Press F4 or F9 and scroll to Pulse L. (S), low weld current pulse time.
- Press F5 or F10 and enter Low weld current pulse time from 0.00~0.99 seconds.
- Press F4 or F9 and scroll to Pre-Gas (S), pre-purge gas time.
- Press F5 or F10 and enter pre-purge gas time from 0.0~9.9 seconds.
- Press F4 or F9 and scroll to Post-Gas (S), post-purge gas time.
- Press F5 or F10 and enter post-purge gas time from 0.0~9.9 seconds.
- Press F4 or F9 and scroll to Strike (A), arc strike weld current.
- Press F5 or F10 and enter arc strike weld current from 0.1~25.0 amps.
- Press Foot Control to maximum and hold for duration of weld
- Press F6 Print Weld wave form graphics from integral printer

WELD MANUAL SCREEN DISPLAY

- F1, Start/Stop, used for manual Start/Stop operations without a foot control.
- F2, Main Menu, returns to the Main Menu display.
- F3, Weld Orbital, returns to the Weld Orbital display.
- F4, Scroll UP, scrolls the highlighted field from one demand parameter to the next demand parameter.
- F5, Adjust Up, increases the numerical value of the demand parameter selected. As this button is pressed for each parameter a vertical bar graph displays the increasing value, both numerically and graphically from the bar graph. For most parameters, a maximum value is obtained once the vertical bar graph has reached the top of the scale. Also, there is a change in the sound once the top of the scale has been reached. The sound changes from a single beep to a triple beep.
- F6, Print Weld, Data-Monitoring of manual weld produces a graphical real time wave form of welding amps and arc volts.
- F7, Pedal On, selects the variable remote foot control for operation.
- F7, Pedal Off, selects the On/Off switch control and permits additional programming of weld current Upslope time in seconds and Final Slope weld current time in seconds.
- F8, Blank, no function control.
- F9, Scroll Down, scrolls the highlighted field from one demand parameter to the next demand parameter.
- F10, Adjust Down, decreases the numerical value of the demand parameter selected. As this button is pressed for each parameter a vertical bar graph displays the decreasing value, both numerically and graphically from the bar graph. For most parameters, a minimum value is obtained once the vertical bar graph has reached the bottom

Section 8

Weld Orbital

of the scale. Also, there is a change in the sound once the bottom of the scale has been reached. The sound changes from a single beep to a triple beep.



From the MAIN MENU screen press this button to select orbital welding. Once at the WELD ORBITAL screen, use the RECALL PROGRAM button at the bottom of the screen to select from the library of customer designed and saved procedures, or return to the MAIN MENU and use the APG (Auto Procedure Generation) function in order to design a new weld procedure. Use the SCROLL UP, SCROLL DOWN, ADJUST UP, and ADJUST DOWN buttons to select and modify specific weld procedure parameters. Then when all variables are set, press the START/STOP button to initiate the welding process.

Once at the WELD ORBITAL screen, the last orbital weld procedure is displayed from memory. This is the default procedure and ready to weld. If a different weld procedure is desired, it can either be recalled from memory or, developed using the Auto Program Generator (APG).

Start/Stop

Pressing this button will start the prepurge gas flowing and start the welding procedure.

Main Menu

Press this button to return to the MAIN MENU.

Print Weld

Press the PRINT WELD button to obtain a printout of the last weld procedure parameters and the wave form strip chart of the completed weld.

This will give a weld procedure printout, first showing the description of the procedure, followed by the all the welding parameters, then by Limit and Deviation parameters, then by the actual strip chart of the weld current, arc voltage and motor speed.

Scroll Up

Press this button in order to scroll and select the highlighted field from one DEMAND parameter up to the next.

Adjust Up

After the SCROLL UP or SCROLL DOWN buttons have been used to select a parameter to be modified, press the ADJUST UP button to increase the numerical value of that parameter.

As this button is pressed for each parameter a vertical bar graph shows the increasing value, both numerically and in height of the bar graph.

For most parameters, a maximum value is obtained once the vertical bar graph has reached the top of the scale. There is also a change in the sound once the maximum has been reached, from a single 'beep' to a triple 'beep'.

Section 9

Recall Program



Press the RECALL PROGRAM in order to access the library of operator saved weld procedures.

NOTE: If the currently used procedure is not saved, a warning screen of text will prompt for a 'YES' or 'NO' answer: this is the OVERWRITE screen. Anytime there is a potential change to the existing weld procedure, this screen will appear.



If 'NO' is pressed, the screen will return to the WELD ORBITAL screen. If 'YES' is pressed, the screen will change to RECALL USER MEMORY.

Help

Press this button to read a brief description of the RECALL menu button descriptions and functions.

Main Menu

Press this button to return to the MAIN MENU.

Weld Orbital

Press this button to return to the WELD ORBITAL screen.

Scroll Left

Each time this button is pressed, the locations of where each weld procedure is saved will move three number locations to the left.

Locations

The bottom three buttons on this screen indicate the number of the location where weld procedures are saved. Using the SCROLL LEFT and SCROLL RIGHT button, will move the locations accordingly to show the status of each location.

Those locations with the word EMPTY above the number, indicate that there is no weld procedure saved in that location.

Scroll Right

Each time this button is pressed, the locations of where each weld procedure is saved will move three number locations to the right.

Those locations with the word EMPTY above the number, indicate that there is no weld procedure saved in that location.

Section 10

If the current weld program is a temporary, unsaved/modified program, the RECALL screen will be blank. This indicates that the current weld program has not been saved to any location. However, if the current weld program is from one of the saved locations, this screen will display the location it is presently saved at.

Press any button that does not contain the word EMPTY. Press WELD ORBITAL to return to that screen to begin welding with the saved procedure.

Save Program



Once a weld procedure has been developed, it is generally a good idea to save it for use at a later date. In order to do this, simply press the SAVE PROGRAM button. This will change to the SAVE USER MEMORY screen.

Help

Press this button to read a brief description of the SAVE menu button descriptions and functions.

Main Menu

Press this button to change to the MAIN MENU.

Weld Orbital

Press this button to change to the WELD ORBITAL screen.

Communication Menu

Press this button to change to the COMMUNICATION MENU.

Scroll Left

Each time this button is pressed, the locations of where each weld procedure is saved or can be saved to, will move three numbers to the left.

Those locations with the word EMPTY above the number, indicate that there is no weld procedure saved in that location.

Locations



When a location button is pressed, and if that location is already occupied with a weld procedure, another screen will appear with an OVERWRITE VERIFY message.



If the current procedure is to be saved at this location, press “YES”. If this location is to be emptied, and the saved weld procedure erased, press “EMPTY ONLY”. If nothing is to be done with this location, and you need to return to the SAVE PROGRAM MENU, press “NO”.

Scroll Right

Each time this button is pressed, the locations of where each weld procedure is saved or can be saved to, will move three numbers to the right.

Those locations with the word EMPTY above the number, indicate that there is no weld procedure saved in that location.

Weld Mode

Pressing this button will toggle the high voltage arc starter from the prompt READY TO WELD (high voltage enabled) to READY TO TEST (high voltage disabled). This toggle is visible at the bottom of the WELD ORBITAL screen.

Scroll Down

Press this button in order to scroll the highlighted field from one DEMAND parameter down to the next. Adjustment of each parameter is performed using the ADJUST UP or ADJUST DOWN buttons.

Adjust Down

After the SCROLL UP or SCROLL DOWN buttons have been used to select a parameter to be modified, press the ADJUST DOWN button to decrease the numerical value of that parameter.

As this button is pressed for each parameter a vertical bar graph shows the decreasing value, both numerically and in height of the bar graph.

For most parameters, a minimum value is obtained once the vertical bar graph has reached the bottom of the scale. There is also a change in the sound once the minimum has been reached, from a single ‘beep’ to a triple ‘beep’.

Section 11

Auto Program Generator



From the main menu screen press Auto Prog. The ease of using the CobraTig 150 SM comes primarily from this feature. By simply inputting

some basic tube or pipe variables, the CobraTig 150 SM digital controller can generate and produce a near ideal weld procedure.

The following menu will guide the operator through basic fields of information entry. Beginning with selections for tube or pipe and diameter and wall thickness. Additional information can be designed into the procedure that include different pulse types, up to 5.0 seconds motor delay time, multiple revolutions, and programming of up to 7 opposing tacks.

Help

Press this button to read a brief description of the APG button descriptions and functions.

Ignore Entries

Pressing this button at any time during the design of a weld procedure, will automatically return the program to the MAIN MENU and lose all entered information.

Accept Entries

Once the first three variables are entered into the APG screen this button may be pressed, thus bypassing any additional features and changing directly to the WELD ORBITAL screen.

Previous Entry

Press this button to return to the previous field in order to change the entered value.

Next Entry

Press this button to jump to the next field in order to change the entered value or add a new value.

Gas On/Gas Off

This button is used to manually toggle the gas flow either "ON" OR "OFF". This button is used to indicated the **status** of the gas flow.

When the button reads "GAS ON", the gas solenoid valve is open and the gas flowing.

When the button reads "GAS OFF", the gas solenoid valve is closed and the gas is not flowing.

Section 12

Print Menu

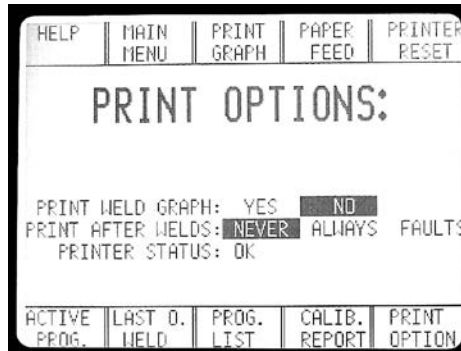

At the PRINT MENU, many different aspects of the CobraTig 150 SM can be printed or modified. Not only can various printouts of weld procedures, list of procedures, and calibration reports be made but the printer configuration can be modified to print on command or automatically.

Help

Press this button to read a brief description of the PRINT MENU button descriptions and functions.

Main Menu

Press this button to return to the MAIN MENU.

Print Graph

This function works with the Printer After Welds function. Pressing this button toggles the command from YES (prints weld procedure parameters plus **entire** weld graph), to NO (prints weld procedure parameters **only**).

Paper Feed

Press and hold this button down in order to feed paper through the printer driver mechanism. This is especially useful after loading a new roll of paper.

Printer Reset

Should the printer run out of paper either during a PRINT WELD or while feeding, the PRINTER STATUS field will read as follows, "ERROR, OUT OF PAPER".

Once a new roll of paper has been loaded and fed through using the PRINTER FEED button, press the PRINTER RESET button once. This should return the PRINTER STATUS field to read, "OK".

To load a new roll of paper, slide printer tray straight out until it stops. Disengage the Printer Drive Mechanism by lifting up the Drive Latch Arms on either side of the printer. Unroll approximately 4 to 6 inches of paper from the roll and feed through the slot, pushing the paper through until it emerges from the front panel of the printer tray.

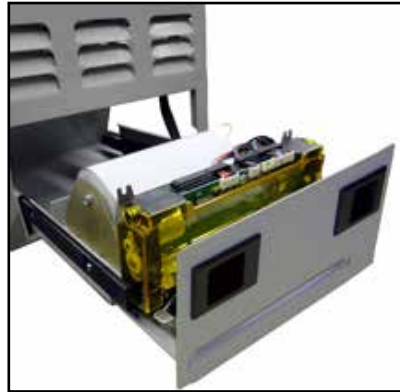

Pull up any extra slack in the paper. Lower the Drive Latch Arms to secure the Printer Drive Mechanism.

Feed Paper Through Slot

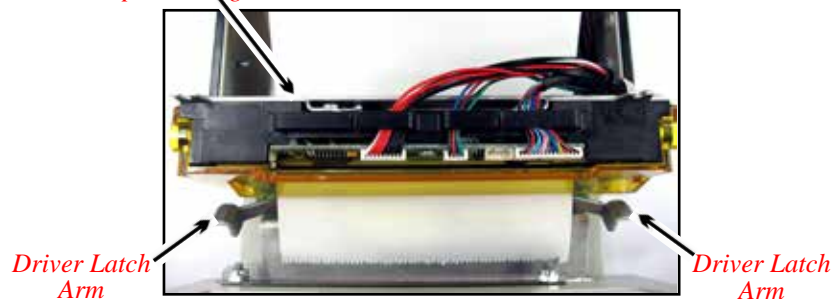

Press the PRINTER FEED button to align paper in Drive, then press the PRINTER RESET button.

Active Program

Press this button in order to print the current weld procedure that is loaded on the memory of the unit.

Last Orbital Weld

Press this button to obtain a printout of the last completed orbital weld. This will give the same results as the PRINT WELD button on the WELD ORBITAL screen.

This will give a weld procedure printout, first showing the description of the procedure, followed by the all the welding parameters, then by Limit and Deviation parameters, then by the actual strip chart of the weld amperage, arc voltage and motor speed.

Program List

Press this button to printout the complete listing of all the weld procedures saved in the memory of the unit.

Calibration Report

To obtain a printout of the calibration values for the motor, motor-tachometer feedback, current and voltage scales, press this button.

Print Option

This button controls the Deviation Report printout after each weld. There are only three options available for this printout, they are as follows: NEVER, ALWAYS & FAULTS.

In the NEVER mode, a printout of the weld will only occur if the PRINT WELD button is pressed.

In the ALWAYS mode, at the end of every weld once the rotor returns to the home position, it will automatically printout the resultant Strip Chart as if the PRINT WELD button had been pressed.

In the FAULTS mode, a Strip Chart will only printout if there were deviations in the weld sequence.

Section 13

Calibration Menu

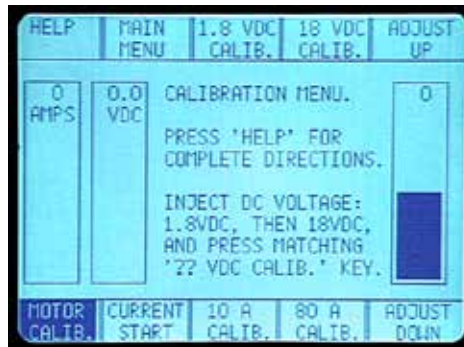

Prior to using the CobraTig 150 SM unit for welding, it is generally a good idea to calibrate the output and feedback readings prior to striking an arc. Options from the CALIBRATION MENU include motor output and tachometer feedback, current output and feedback, and arc voltage input.

In order to properly calibrate this machine, you will need the following: DC power supply capable of producing 1.0 VDC to 20.0 VDC, a certified digital multimeter, and various standard connection leads. To aid in the calibration of this machine, purchase kit P/N 005-0251 (The instructions included with the kit are for the model ACL Orbital Welder, they do not apply to this unit). Use the instructions on the HELP screen for a full explanation on how to calibrate this unit.

Help

Press this button to read a brief description of the CALIBRATION MENU button descriptions and functions.

Main Menu

Press this button to return to the MAIN MENU.

1.8 VDC Calibration / 18 VDC Calibration

These two keys are used in conjunction for calibrating the arc voltage feedback circuit. Use the information on the HELP screen to perform this calibration procedure.

Connect an external DC voltage power supply to the shunt connectors labeled 'ARC VOLTAGE' and adjust to 1.8 VDC input. Reference the VDC bar graph on the LCD screen, press the 1.8 VDC button, this will set the calibration.

Set the input to 18.0 VDC and repeat the above process. The procedure will cycle through twice for an average reading and setting, then quit when ready.

Adjust Up

Press this button to adjust the bar graph setting to match that of the reference value being read - voltage or current.

Motor Calibration

With the weldhead plugged into the CobraTig 150 SM rear panel, the motor voltage output to the weldhead, and tachometer feedback from the weldhead rotor can be calibrated.

This screen will allow the operator to calibrate any orbital weldhead, at any speed value, between 1.0 and 10.0 rpm. Using the HIGH/LOW

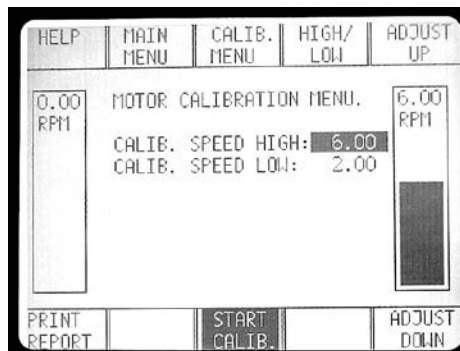

button, select the respective speed value and use the ADJUST UP and ADJUST DOWN buttons to select the rpm value required.

The HIGH and LOW values can never be equal. A minimum of 1.0 rpm will separate the two values. If the LOW value is increased, the HIGH will increase, with the 1.0 rpm difference between them. Similarly, if the HIGH is decreased, the LOW will decrease with the 1.0 rpm difference.

Feedback of the weldhead during calibration is seen in the bar graph on the left side of this screen.

High/Low

Toggles between the HIGH and LOW rpm speed values.

Print Report

Press this button, once calibration is complete, to view a printed report of the calibration values.

The calibration values shown are an indication of the MOTOR/TACH status of the weldhead. A typical printout is shown below:

MOTOR Calibration report			
MOTOR gain:	-4.6%	Zero offset:	0.30 RPM
TACH gain:	1.9%	Zero offset:	0.02 RPM

Should these MOTOR & TACH values return with number of 0.00% and 0.00 RPM, the calibration was invalid and should be re-run. Continuous results of all zeros, is an indication that the weldhead is in need of service.

Consult the weldhead owner's manual for proper maintenance and calibration service.

MOTOR Calibration report			
MOTOR gain:	0.0%	Zero offset:	0.00 RPM
TACH gain:	0.0%	Zero offset:	0.00 RPM

NOTE: If all values for MOTOR or WELDER calibration are zeros, it means that the calibration did not complete successfully and is not valid.

Start Calibration

Press this button to start the weldhead calibration procedure. The calibration starts at the values selected using the "ADJUST UP" and "ADJUST DOWN" buttons.

Current Start

Using the calibration kit and the multimeter, calibration of the output current can be achieved in relatively short time. Using the 10 A CALIBRATION and 80 A CALIBRATION buttons, output values at these points will properly calibrate the current for almost all applications.

10A Calibration / 80A Calibration

These two keys are used in conjunction for calibrating the output current. Use the information on the HELP screen to perform this calibration procedure.

Connect the multimeter to the shunt labelled CURRENT, set the tungsten arc gap and the gas setting and press CURRENT START. Once the 10 A arc is established, use the ADJUST UP and ADJUST DOWN buttons to reach 2.50 mV on the multimeter. Once this mV value is read, press the 10 A button, this will automatically jump the current to the 80 A output value.

Use the UP and DOWN buttons to set the mV value to 20.0 mV, then press 80 A. This cycle will repeat once more then quit when ready. Once the arc is extinguished, the output current has been calibrated.

Adjust Down

Press this button to adjust the bar graph setting to match that of the reference value being read - voltage or current.

Section 14

Communication Menu



It is from this screen that weld procedures can be transferred from one CobraTig 150 SM unit to another. There are two paths available for transmission: IR (Infra Red) and Wired Cable. The IR method works much like a TV remote, just have the two units facing each other at a distance up to 10 feet and commence transmitting. While the Wired Cable is a cable hookup between the units' RS232 transmission ports on the rear panels.

Help

Press this button to read a brief description of the CALIBRATION MENU button descriptions and functions.

Main Menu

Press this button to return to the MAIN MENU.

Section 15

Save Menu

Press this button to change to the SAVE MENU.

Xmit Channel

This button will toggle between two choices of transmission. Either Infra Red or Wired Cable.

Start Receive

To begin transmitting a procedure to another machine, press this button.

Scroll Left

Each time this button is pressed, the locations of where each weld procedure is saved or can be saved to, will move three numbers to the left.

Those locations with the word EMPTY above the number, indicate that there is no weld procedure saved in that location.

Locations

In order to transmit a procedure, first locate the location number of where the procedure is saved. Then press the applicable button to send. The START RECEIVE button will then toggle to show STOP XMIT, prompting the operator to cancel the transmission when pressed.

On the receiving unit, simply press the START RECEIVE button to saved the transmitting procedure, then press the location number of where the procedure is to be saved. If the procedure is saved to a location that is empty, the EMPTY label will disappear once the procedure is saved.

Scroll Right

Each time this button is pressed, the locations of where each weld procedure is saved or can be saved to, will move three numbers to the right.

Those locations with the word EMPTY above the number, indicate that there is no weld procedure saved in that location.

Setup Menu



This menu is used to set up the user's preferences of the weld procedure serialization, button clicks and sounds, and LCD display contrast.

Help

Press this button to read a brief description of the SETUP MENU button descriptions and functions.

Main Menu

Press this button to change to the MAIN MENU.

Decrease S/N

This button will DECREASE the starting serial number of the next orbital weld. The serial number is incremented before every weld, so use one number less than actual number of next weld.

Section 16

Increase S/N

This button will INCREASE the starting serial number of the next orbital weld. The serial number is incremented before every weld, so use one number less than actual number of next weld.

Higher Contrast

Press this button to increase the contrast for the LCD screen. This will make the display darker as the number increases.

Change Units

Press this button to toggle units from INCHES to METRIC. It will only affect the screen display when using AUTO PROCEDURE GENERATION, see MAIN MENU.

Change Sound

Press this button to enable or disable sound.

Change Click

Press this button to enable or disable button clicks.

Change Light

This toggles the LCD backlight either ON or OFF. The AUTO setting will sense ambient light and change the backlight to adjust accordingly.

Lower Contrast

Press this button to decrease the contrast for the LCD screen. This will make the display lighter as the number decreases.

Diagnostic Menu

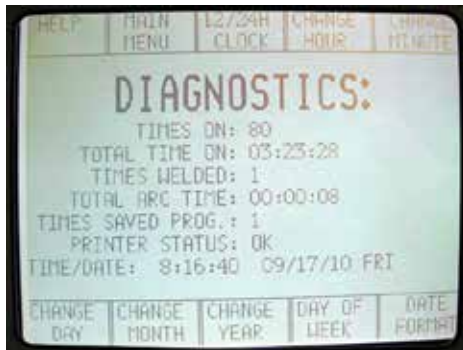

This screen will show the units internal total on-time diagnostics. This includes number of times unit was powered on, the total on-time, the number of welds performed, total arc time and number of times a weld procedure was saved.

Help

Press this button to read a brief description of the DIAGNOSTIC MENU button descriptions and functions.

Main Menu

Press this button to return to the MAIN MENU.

Pressing each of the buttons below, will change the display settings of the TIME/DATE stamp within the CobraTig unit. The TIME/DATE stamp will show on the MAIN MENU display screen and at the bottom of every Post-Weld, Weld Deviation or Printed Chart page.

For each field below, a subsequent button press will increase the value range by one. Once the end of the range is reached, that field sequence will roll-over and start again.

12/24H Clock

Pressing this button will toggle the AM or PM from the screen and change the hour of the day, from 1-12 to 0-23, and back.

Change Hour

Press to increase the hour of the day. In 12 Hour mode, the AM/PM will change automatically.

12-Hour Range: 1 -12 AM & 1 - 12 PM

24-Hour Range: 0 - 23

Change Minute

Press to increase the minute of the hour. Once the end of the range is reached, the sequence will revert again.

Range: 0 - 59.

Change Day

Press to increase date of the month.

Range: 1 - 31.

Change Month

Press to increase the change of month.

Range: Jan - Dec

Change Year

Press to increase the year.

Range: 09 - 37

Change Day of Week

Press to increase the day of the week.

Range: SUN - SAT

Change Format

Press to toggle display.

Range: "MM/DD/YY DAY", "DD/MM/YY DAY", "MMM DD, YYYY"

THIS PAGE INTENTIONALLY BLANK

LIMITED WARRANTY

Effective August 1, 2010

This warranty supersedes all previous MK Products warranties and is exclusive, with no other guarantees or warranties expressed or implied.

LIMITED WARRANTY - MK Products Inc., Irvine, California warrants that all new and unused equipment furnished by MK Products is free from defects in workmanship and material as of the time and place of delivery by MK Products. No warranty is made by MK Products with respect to trade accessories or other items manufactured by others. Such trade accessories and other items are sold subject to the warranties of their respective manufacturers, if any.

MK Products' warranty does not apply to components having normal useful life of less than one (1) year, such as relay points, wire conduit, tungsten, and welding gun parts that come in contact with the welding wire, including gas cups, gas cup insulators, and contact tips where failure does not result from defect in workmanship or material.

MK Products shall, exclusively remedy the limited warranty or any duties with respect to the quality of goods, based upon the following options:

- (1) repair
- (2) replacement
- (3) where authorized in writing by MK Products, the reasonable cost of repair or replacement at our Irvine, California plant.

As a matter of general policy only, MK Products may honor an original user's warranty claims on warranted equipment in the event of failure resulting from a defect within the following periods from the date of delivery of equipment to the original user:

1. Power Supplies and Wire Feed Cabinets 3 years
2. Weldheads, Coolers, Positioners, and Push-Pull Guns ...1 year
3. Spool Guns, and Spool Gun Modules 180 days
4. Repairs/Exchanges/Parts 90 days

Classification of any item into the foregoing categories shall be at the sole discretion of MK Products. Notification of any failure must be made in writing within 30 days of such failure.

A copy of the invoice showing the date of sale must accompany products returned for warranty repair or replacement.

All equipment returned to MK Products for service must be properly packaged to guard against damage from shipping. MK Products will not be responsible for any damages resulting from shipping.

Normal surface transportation charges (one way) for products returned for warranty repair or replacement will be borne by MK Products, except for products sold to foreign markets.

ANY EXPRESS WARRANTY NOT PROVIDED HEREIN AND ANY IMPLIED WARRANTY, GUARANTY, OR REPRESENTATION AS TO PERFORMANCE, AND ANY REMEDY FOR BREACH OF CONTRACT WHICH, BUT FOR THIS PROVISION, MIGHT ARISE BY IMPLICATION, OPERATION OF LAW, CUSTOM OF TRADE, OR COURSE OF DEALING, INCLUDING ANY IMPLIED WARRANTY OF MERCHANTABILITY OR OF FITNESS FOR PARTICULAR PURPOSE, WITH RESPECT TO ANY AND ALL EQUIPMENT FURNISHED BY MK PRODUCTS, IS EXCLUDED AND DISCLAIMED BY MK PRODUCTS.

EXCEPT AS EXPRESSLY PROVIDED BY MK PRODUCTS IN WRITING, MK'S PRODUCTS ARE INTENDED FOR ULTIMATE PURCHASE BY COMMERCIAL/INDUSTRIAL USERS AND FOR OPERATION BY PERSONS TRAINED AND EXPERIENCED IN THE USE AND MAINTENANCE OF WELDING EQUIPMENT AND NOT FOR CONSUMERS OR CONSUMER USE. MK PRODUCTS' WARRANTIES DO NOT EXTEND TO, AND NO RE-SELLER IS AUTHORIZED TO EXTEND MK PRODUCTS' WARRANTIES TO ANY CONSUMER.

USE OF OTHER THAN **GENUINE** MK PRODUCTS' CONSUMABLES, PARTS, AND ACCESSORIES MAY INVALIDATE YOUR PRODUCT WARRANTY.



16882 Armstrong Ave.
Irvine, CA 92606
Tel (949)863-1234 Fax (949)474-1428
www.mkproducts.com

DATE: August 1, 2010



PRODUCTS

16882 ARMSTRONG AVE.

IRVINE, CA 92606

TEL (949) 863-1234 FAX (949) 474-1428

WWW.MKPRODUCTS.COM