

PackRat™

II

TRAVEL CARRIAGE SYSTEM

OWNER'S MANUAL

Applies to Model nos.

128-216, 128-226, 128-236

128-211, 128-221, 128-231

128-212, 128-222, 128-232

128-215, 128-225

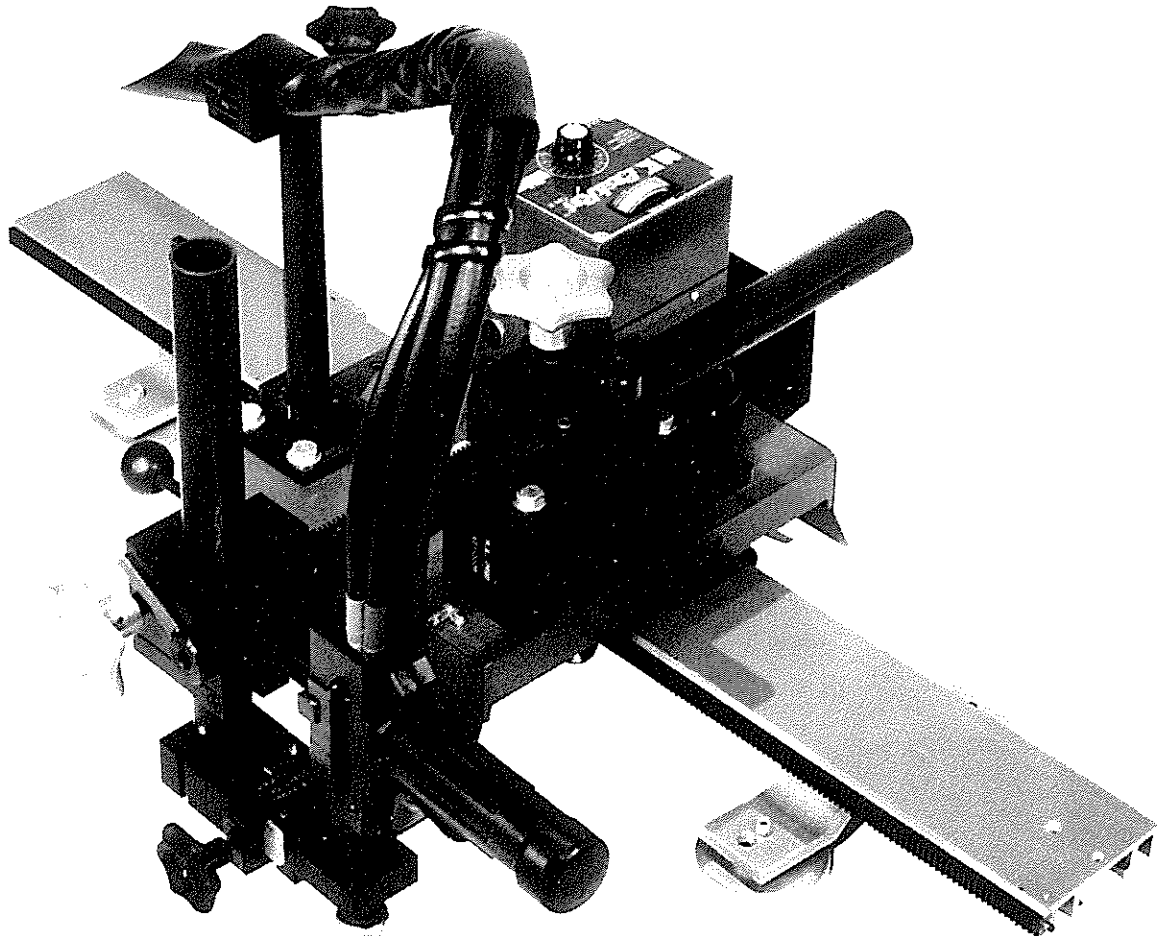

Effective with Serial No.
0700 J81

Additional Copy Price \$2.50
P/N 091-0125

M.K. PRODUCTS, INC. • 16882 ARMSTRONG AVE. • IRVINE, CALIFORNIA 92714
714-863-1234 • TELEX 69-2369

For your protection in the event of theft, loss, or warranty service, please fill in the information requested below:

Model No. _____ Date of Purchase _____

Serial No. _____

Dealer Purchased From _____

This manual details the installation and operation of the Pack Rat II® Travel Carriage System. Properly installed, adjusted and maintained for your application, the Pack Rat II will prove to be a reliable system providing a consistent operation when cutting or welding.

In order to assure optimum performance of your Pack Rat Travel Carriage System, familiarize yourself with the contents of this manual and carefully follow all instructions.

This manual will not only guide you when installing your Pack Rat System but will also be a handy reference for replacement parts and optional accessories.

LIMITED WARRANTY

LIMITED WARRANTY—M.K. Products, Inc., Irvine, California warrants to customer that all new and unused equipment furnished by M.K. Products is free from defect in workmanship and material as of the time and place of delivery by M.K. Products. No warranty is made by M.K. Products with respect to trade accessories or other items manufactured by others. Such trade accessories and other items are sold subject to the warranties of their respective manufacturers, if any.

M.K. Products warranty does not apply to components having normal useful life of less than one (1) year, such as relay points, wire conduit and welding torch parts that come in contact with the welding wire including gas cups, gas cup insulators and contact tips where failure does not result from defect in workmanship or material.

In the case of M.K. Products' breach of warranty or any other duty with respect to the quality of any goods, the exclusive remedies therefor shall be at M.K. Products' option (1) repair or (2) replacement or (3) where authorized in writing by M.K. Products the reasonable cost of repair or replacement at our Irvine, Calif. plant or (4) payment of or credit for the purchase price (less reasonable depreciation based upon actual use) upon return of the goods at M.K. Products' risk and expense via normal surface transportation. Upon receipt of notice of apparent defect or failure, M.K. Products shall instruct the claimant on the warranty claim procedures to be followed.

As a matter of general policy only, M.K. Products may honor an original user's warranty claims on warranted equipment in the event of failure resulting from a defect within ninety (90) days from the date of delivery of Equipment to the original user

A copy of the distributor's invoice to the end user, showing the date of sale, must accompany products returned for warranty repair or replacement.

Normal surface transportation charges (both ways) for products returned for warranty repair or replacement will be borne by M.K. Products except for products sold for foreign markets.

ANY EXPRESS WARRANTY NOT PROVIDED HEREIN AND ANY IMPLIED WARRANTY, GUARANTY OR REPRESENTATION AS TO PERFORMANCE AND ANY REMEDY FOR BREACH OF CONTRACT WHICH, BUT FOR THIS PROVISION, MIGHT ARISE BY IMPLICATION, OPERATION OF LAW, CUSTOM OF TRADE OR COURSE OF DEALING, INCLUDING ANY IMPLIED WARRANTY OF MERCHANTABILITY OR OF FITNESS FOR PARTICULAR PURPOSE, WITH RESPECT TO ANY AND ALL EQUIPMENT FURNISHED BY M.K. PRODUCTS IS EXCLUDED AND DISCLAIMED BY M.K. PRODUCTS.

EXCEPT AS EXPRESSLY PROVIDED BY M.K. PRODUCTS IN WRITING, M.K. PRODUCTS ARE INTENDED FOR ULTIMATE PURCHASE BY COMMERCIAL/INDUSTRIAL USERS AND FOR OPERATION BY PERSONS TRAINED AND EXPERIENCED IN THE USE AND MAINTENANCE OF WELDING EQUIPMENT AND NOT FOR CONSUMERS OR CONSUMER USE. M.K. PRODUCTS WARRANTIES DO NOT EXTEND TO, AND NO RESELLER IS AUTHORIZED TO EXTEND M.K. PRODUCTS' WARRANTIES TO ANY CONSUMER.

INDEX

PAGE

- 2. INTRODUCTION
- 3. SAFETY REGULATIONS
 - A. TRACK MOUNTING
 - B. TRACTOR UNIT
 - C. RACK AND TUBE ASSEMBLIES
 - D. MANIFOLD, VALVE AND SOLENOID ASSEMBLIES
- 4. SPECIFICATIONS
 - A. SYSTEM BREAKDOWN
 - B. TRACK LOAD CAPACITY
 - C. TRAVEL CARRIAGE LOAD CAPACITY
 - D. MOUNTING POSITIONS
 - E. TRACK WEIGHTS
 - F. COMPONENT WEIGHTS
 - G. TRACTOR PLATE OUTLINE DRAWING
- 6. INSTALLATION INSTRUCTIONS
- 7. OPERATION
- 8. TROUBLE SHOOTING
- 8. MAINTENANCE
- 9. FEATURES
- 10. SINGLE CUTTING TORCH SYSTEM PARTS LIST
- 11. DUAL CUTTING TORCH SYSTEM PARTS LIST
- 12. COBRA/UNIVERSAL MIG SYSTEM PARTS LIST
- 13. PACK RAT II WIGGLER/COBRAMATIC SYSTEM PARTS LIST
- 14. TRAVEL CARRIAGE ASSEMBLY EXPLODED VIEW AND PARTS LIST
- 15. CONTROL BOX ASSEMBLY EXPLODED VIEW AND PARTS LIST
- 16. PARTS LIST - COMPONENT BREAKDOWN
- 25. OPTIONAL ACCESSORIES
- 27. WIRING SCHEMATIC

INTRODUCTION

The M.K. Products Pack Rat II® Travel Carriage System is designed to move along a rugged precision extruded aluminum track with an incorporated steel gear rack. A wide range of automatic and semi-automatic flame cutting and MIG welding functions can easily be achieved using the standard racking configurations available with each system. This unmatched welding and cutting system can be used in all positions to save time, increase production, and improve accuracy. All racking assemblies may be arranged to allow plasma cutting, plasma welding, circle cutting, flame treating, descaling, TIG welding and special equipment set-ups such as welding x-ray equipment, ultrasonic welding equipment, and non-flammable spraying or coating. Standard systems include Single Cutting, Dual Cutting, Cobra/Universal MIG, and Wiggler/Cobramatic set-ups.

Horizontal, vertical, and out of position applications can easily be achieved using the appropriate mounting brackets for each position. (See Pages 22 and 23) All Pack Rat II® Travel Carriages are capable of carrying loads up to 200 lbs. (90 kg) horizontal and 50 lbs. (22 kg) vertical when using the proper mounting brackets and adhering to the safety regulations on Page 3. An optional limit switch may also be used in conjunction with the Travel Carriage Assembly to permit automatic shut off in any position with the use of a limit switch stop. (See Page 25)

All Pack Rat II® Travel Carriage Systems are capable of adapting to applications requiring speeds of 0-6 IPM (0-15cm/min), 3-60 IPM (7.6-150cm/min) standard, or 18-180 IPM (45-450cm/min). (See Pages 10, 11, 12 and 13) These Travel Carriage Assemblies are solid state controlled, high frequency protected, and offer a high degree of accuracy and repeatability. The cam locking assembly allows existing systems set up for one speed to be converted to another speed with only a change of the control box.

Four independent racking configurations are available as completed assemblies. (See Pages 16 and 17) Each configuration may be mounted in various positions and all racking assemblies may be rearranged for custom applications. Additional racking components may also be added to existing systems to allow greater racking flexibility.

A complete line of torch holder assemblies are available for use with all racking assemblies. (See Pages 19, 20 and 21) These holders are capable of holding diameters ranging from 5/8" (16mm) to 1 3/4" (44mm) depending on the individual holder being used. The standard torch holder assemblies have a stud mounting feature which mounts directly into the racking assembly clamp block. An optional quick disconnect torch holder assembly is also available which mounts directly to a quick disconnect clamp allowing the torch to be removed and serviced without changing the tip to work distance.

Standard and heavy duty straight sections of extruded aluminum track are available in 4' (120cm), 6' (180cm), 8' (240cm) and 12' (360cm) lengths. (See Page 22) Each track section may be coupled with another track section using a unique quick release track clamp kit. All track assemblies have a pin at one end to allow rapid alignment when joining two or more track assemblies together.

A variety of mounting brackets for magnetic and non-magnetic applications may be used on both standard and heavy duty track. (See Page 23) Two inch (51mm), three inch (76mm), and heavy duty magnetic mounting brackets are available for steel surfaces and stud or suction mounting brackets are available for non-ferrous surfaces. Care should be taken in selecting the proper mounting bracket for each application.

An accessory 115 VAC outlet is provided and connected to the input line cord to be on whenever the line cord is plugged in. This outlet connection may be moved internally to other terminals to provide switching by the main switch or limit switch (if used), or a combination of the two. The main on-off switch is used to start and stop the unit without changing the speed adjustment and a forward/reverse switch will change direction while in motion.

A wide selection of optional accessories may be used with the Pack Rat II® Travel Carriage System. (See Pages 25 and 26) These include a limit switch assembly, multi-direction block, torch floater assembly, trailer hitch, gas solenoid, circle cutter, and other accessories designed to aid in the operation of the Pack Rat II System.

Read the contents of this manual carefully prior to operating this equipment. Both safety and maintenance are emphasized throughout the manual to allow for safe operation at all times. Thoroughly read the safety regulations on the opposite page before proceeding any further.

CAUTION

SAFETY REGULATIONS

READ THIS SECTION BEFORE ATTEMPTING TO UTILIZE THIS EQUIPMENT

I. Track Mounting:

The track is mounted by use of mounting brackets which may be attached by bolts, studs, vacuum cups or magnets. It is the responsibility of the user to ascertain that the mounting is adequate to support the load impressed by the tractor unit, attached equipment and any cable, hose, conduit, or other appendages.

The load capacities of each mounting bracket are given with the mounting method, magnetic, vacuum, etc.

IN NO EVENT SHOULD MAGNETICALLY OR VACUUM MOUNTED TRACKS BE INSTALLED OVERHEAD, VERTICALLY OR HORIZONTALLY WHERE FAILURE OF THE ATTACHMENT COULD RESULT IN EQUIPMENT DAMAGE OR PERSONNEL HAZARD. IN SUCH CASES BOLT OR STUD MOUNTING WITH AT LEAST ONE BRACKET FOR EACH FOUR FEET OF TRACK SHOULD BE UTILIZED.

II. Tractor Unit:

The tractor unit is equipped with a safety pin for the track clamping lever. This pin must always be in place when release of the tractor from the track can result in possible equipment damage or personnel hazard. The drive gear engagement lever has only a detent (no lock or pin). Release of this engagement lever or failure of the drive gear train will result in the tractor unit being free to move along the track with no restraint.

WHEN OPERATING THE TRACTOR IN ANY POSITION WHERE RELEASE OF THE DRIVE GEAR OR FAILURE OF THE DRIVE GEAR TRAIN MAY RESULT IN UNCONTROLLED MOVEMENT OF THE TRACTOR ON THE TRACK, APPROPRIATE MEANS MUST BE TAKEN TO PREVENT THE TRACTOR FROM CAUSING DAMAGE.

Typically — when operated with the track in a vertical position, a safety line should be provided to arrest the fall of the tractor and attached equipment in the event of drive gear release or gear train failure.

A limit switch is available to shut off the tractor drive motor when the tractor reaches a pre-determined position. This switch should always be utilized when there is a possibility of the tractor driving off the end of the track.

FOR APPLICATIONS WHERE THE POSSIBILITIES OF THE TRACTOR DRIVING OFF THE TRACK PRESENTS POSSIBLE EQUIPMENT OR PERSONNEL HAZARDS, PROVISION MUST BE MADE (SUCH AS A SAFETY LINE) TO PREVENT THE UNIT FROM FALLING WHEN REACHING THE END OF THE TRACK.

III. Rack and Tube Assemblies:

The Rack and Tube Assemblies provide for the convenient and precise adjustment of the position of attached equipment. The tube assemblies may be easily removed from the rack blocks. WHEN UTILIZED IN OTHER THAN A HORIZONTAL POSITION, THE WEIGHT OF THE ATTACHMENT MAY CAUSE THE RACK TUBE TO FALL OUT OF THE RACK BLOCK WHEN THE RACK TUBE LOCK IS RELEASED.

Safety retainers are available for the rack tube ends which will prevent the removal of the rack tube assemblies and should be installed for all non-horizontal rack tube applications.

IV. Manifold, Valve and Solenoid Assemblies Utilized With Oxy-Fuel or Similar Cutting System:

The manifold is designed to utilize industry standardized fittings. Normal safety procedures for the use of these gasses must be followed.

IN PARTICULAR — NO LUBRICANT, SEALANT, OR ANY OTHER FOREIGN MATERIAL SHOULD BE USED ON FITTINGS, VALVES, HOSES OR MANIFOLDS UTILIZED FOR OXYGEN.

CONSULT SAFETY PROCEDURES AVAILABLE FROM YOUR GAS SUPPLIER BEFORE ATTEMPTING TO UTILIZE ANY OXYGEN CARRYING COMPONENTS.

SPECIFICATIONS

MODEL NO.	TYPE	TRAVEL SPEED I.P.M. (cm/min)	GEAR RATIO	SYSTEM WEIGHT
128-216	COBRA/UNIVERSAL MIG SYSTEM	0 To 6 I.P.M. (0 To 15 cm/min)	1471:1	28 lbs (14.1 kg)
128-226	COBRA/UNIVERSAL MIG SYSTEM	3 To 60 I.P.M. (7.6 To 150 cm/min)	96:1	28 lbs (14.1 kg)
128-236	COBRA/UNIVERSAL MIG SYSTEM	18 To 180 I.P.M. (45 To 450 cm/min)	48:1	28 lbs (14.1 kg)
128-211	SINGLE CUTTING TORCH SYSTEM	0 To 6 I.P.M. (0 To 15 cm/min)	1471:1	27 lbs (12.3 kg)
128-221	SINGLE CUTTING TORCH SYSTEM	3 To 60 I.P.M. (7.6 To 150 cm/min)	96:1	27 lbs (12.3 kg)
128-231	SINGLE CUTTING TORCH SYSTEM	18 To 180 I.P.M. (45 To 450 cm/min)	48:1	27 lbs (12.3 kg)
128-212	DUAL CUTTING TORCH SYSTEM	0 To 6 I.P.M. (0 To 15 cm/min)	1471:1	36 lbs (16.3 kg)
128-222	DUAL CUTTING TORCH SYSTEM	3 To 60 I.P.M. (7.6 To 150 cm/min)	96:1	36 lbs (16.3 kg)
128-232	DUAL CUTTING TORCH SYSTEM	18 To 180 I.P.M. (45 To 450 cm/min)	48:1	36 lbs (16.3 kg)
128-215	PACK RAT WIGGLER/ COBRAMATIC	0 To 6 I.P.M. (0 To 15 cm/min)	1471:1	29 lbs (14.5 kg)
128-225	PACK RAT WIGGLER/ COBRAMATIC	3 To 60 I.P.M. (7.6 To 150 cm/min)	96:1	29 lbs (14.5 kg)

NOTE: CONTROLS — SOLID STATE, 115 VAC.
 50/60 Hz INPUT, 90 VDC OUTPUT.
 SYSTEM WEIGHTS DO NOT INCLUDE TRACK OR MOUNTING BRACKETS.

TRACK LOAD CAPACITY

(MAXIMUM NET LOAD)*

STANDARD TRACK	HEAVY DUTY TRACK
100 lbs (45 kg)	200 lbs (90 kg)

*ALL POSITIONS AND LENGTHS.

TRAVEL CARRIAGE LOAD CAPACITY

(MAXIMUM NET LOAD)*

POSITION	TRAVEL SPEED 0 To 6 I.P.M. (0 To 15 cm/min)	TRAVEL SPEED 18-180 I.P.M. (45 To 450 cm/min)
	3 To 60 I.P.M. (7.6 To 150 cm/min)	
HORIZONTAL	200 lbs (90 kg)	100 lbs (45 kg)
VERTICAL	50 lbs (22 kg)	25 lbs (11 kg)

*LOAD CAPACITIES ARE BASED ON TRAVEL CARRIAGE ASSEMBLIES WITHOUT RACKING. RACKING AND HARDWARE MUST BE TAKEN INTO CONSIDERATION WHEN ESTABLISHING LOAD CAPACITIES.

TRAVEL CARRIAGE MOUNTING POSITIONS AND LOAD LIMITS

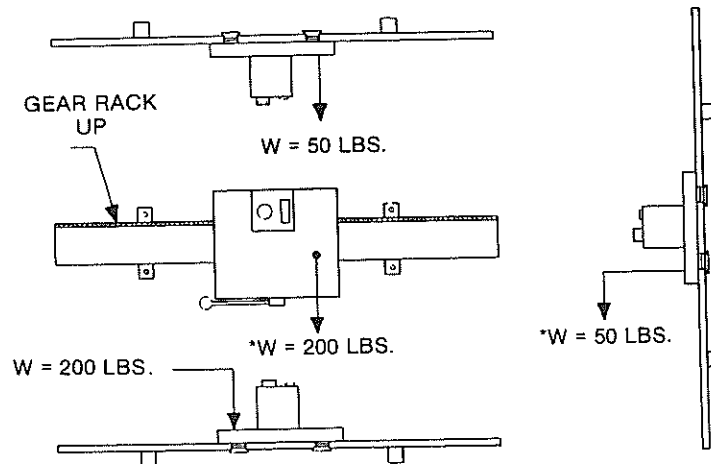

*CENTER OF GRAVITY NOT MORE THAN 5 INCHES FROM TRAVEL CARRIAGE

TRACK WEIGHTS

TRACK	4 ft. (1.20m)	6 ft. (1.80m)	8 ft. (2.40m)	12 ft. (3.60m)
STANDARD	8 lbs. 8 oz. (3.9 kg)	13 lbs. (5.9 kg)	17 lbs. (7.7 kg)	25 lbs. 8 oz. (11.6 kg)
HEAVY DUTY	10 lbs. (4.5 kg)	15 lbs. (6.8 kg)	20 lbs. 8 oz. (9.3 kg)	31 lbs. (14.1 kg)

COMPONENT WEIGHTS

DESCRIPTION	2 in. (50.8mm) MTG. BRKT.	3 in. (76.2mm) MTG. BRKT.	HEAVY DUTY MTG. BRKT.	SUCTION MTG. BRKT.	CUTTING SYSTEM RACKING	DUAL-CUTTING SYSTEM RACKING	COBRA/UNIVERSAL MIG SYSTEM RACKING	WIGGLER/COBRA. SYSTEM RACKING
WEIGHT	1 lb. 8 oz. (.7 kg)	2 lbs. 4 oz. (1.0 kg)	6 lbs. (2.7 kg)	4 lbs. 8 oz. (2.0 kg)	9 lbs. 4 oz. (4.2 kg)	18 lbs. 8 oz. (8.4 kg)	10 lbs. (4.5 kg)	11 lbs. 2 oz. (5.0 kg)

TRACTOR PLATE OUTLINE DRAWING

Dwg. No. 097-0020

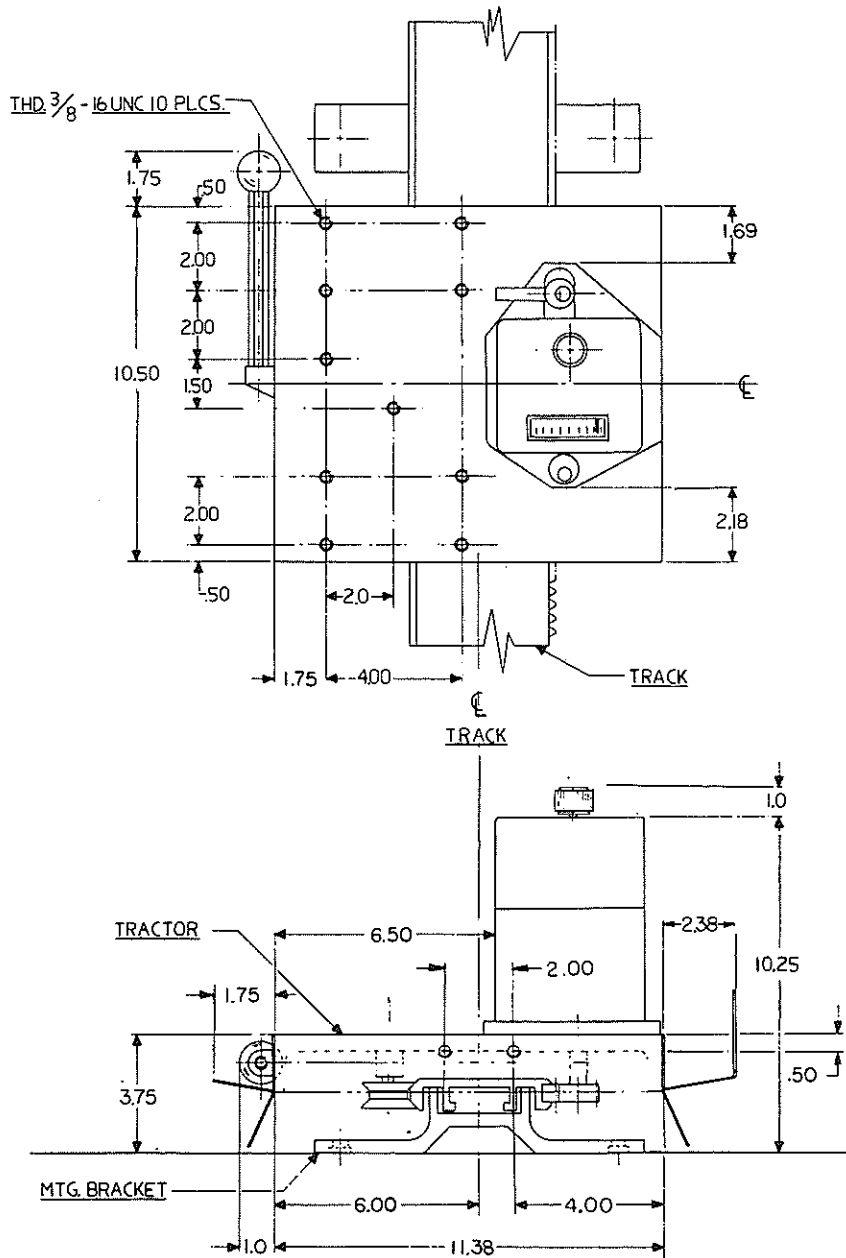

INSTALLATION INSTRUCTIONS

TRACK ASSEMBLY

1. Track Assemblies are available in two types - standard and heavy-duty. See page 4 for track load capacities.
2. Track can be held in place by means of stud brackets, magnetic mounting brackets or unique suction pads with integral pump. The method chosen depends on: 1) Type of material on which the track is mounted. 2) The various positions in which the system will be mounted. See page 4 for load limits and capacities.

CAUTION: Please Read Safety Regulations Carefully, (See Page 3)

3. Track mounting brackets should be positioned at four-foot intervals, unless closer spacing is required.
4. Metal dowel pins at one end of each track section provide proper gear rack alignment. For applications requiring the coupling together of standard and/or heavy-duty track, the Track Clamp Kit P/N 005-0052, is required. Refer to instructions provided with this Kit for proper assembly and installation.
5. See page 22 for detailed parts list of the Track Assemblies.

TRACTOR PLATE

1. Illustrations on pages 10, 11, 12 and 13 clearly detail proper assembly of the Pack Rat II Carriage in its various standard configurations.
2. The Tractor Plate has a pattern of holes, which are spaced to permit easy mounting of any associated accessories. (See page 5)
3. See page 14 for detailed Tractor Plate Assembly exploded view and parts list.

MOUNTING CARRIAGE ON TRACK

(See Page 14)

1. With carriage locking handle released, item 25, engage wheels, item 9, with the side of the track opposite gear rack.
2. Lock carriage in place, engaging motor pinion gear with gear rack by locking handle, item 25.
3. To prevent accidental release of Carriage, insert locking pin, item 5, through the Carriage.
4. Locking handle may be mounted with handle knob, item 26, pointing in either direction — as determined by application.

TRAVEL CARRIAGE ADJUSTMENTS

(See Page 15)

1. For rapid positioning of Travel Carriage on track, rotate cam locking lever, item 47, clockwise. This will disengage the motor pinion gear from the gear rack assembly.

CAUTION: Please Read Safety Regulations Carefully. (See Page 3)

2. If through use, excessive gear backlash develops, proceed as follows:

Engage pinion gear with track gear rack by rotating lever, item 47, counter-clockwise until lever seats between detent, item 40, and stop pin, item 41. Loosen socket head screw, item 48. Insert 3/32" dia. pin in hole provided on the side of cam, item 49. Rotate cam to adjust backlash. A .004" shim between pinion gear and gear rack should be used to set standard backlash. Hold cam in position and retighten screw, item 48. Adjustment is now complete.

3. To mount motor control boxes, use hardware detailed on drawing no. 097-0027, page 15, and adjust for proper backlash as stated in no. 2 above.

RACK BLOCK ADJUSTMENTS

(See Page 19)

1. The Rack Block is designed with a 1/16" wide slot, which provides two clamping functions. The short section clamps on the sides of the gear rack and the large section clamps on the rack tube circumference. To eliminate radial movement or excessive drag on the rack, loosen or tighten the short section by means of screw, item 3.
2. Clamp handle, item 5, can be loosened and repositioned to give the easiest clamping motion. If further adjustment is needed, loosen clamp handle, item 5, and tighten or loosen socket head screw, item 6, and retighten clamping handle.
3. If backlash between rack tube and clamping block is permitting radial movement of the tube, adjust socket head screw, item 3.
4. To replace worn gear located in Rack Block, disassemble Rack Block from system. Remove "E" ring, item 7, on gear shaft, item 1, located on face of block opposite the knob. Pull knob/shaft, item 1, out of the block. Replace worn gear, item 13, in slot. Insert knob/shaft, item 1, engaging gear. Reassemble "E" ring, item 7. Replacement is complete.

CUTTING TORCH HOLDER ADJUSTMENTS

(See Page 19)

1. Adjustment for clamping and radial movement prevention is identical to rack block as stated under Rack Block Adjustments.
2. A safety retainer pin, item 16, is included on all racking assemblies and systems. The safety retainer allows normal adjustment of the Torch but prevents the Torch Block Assembly from falling out when utilized in other than a horizontal position.

CAUTION: Please Read Safety Regulations Carefully.
(See Page 3)

3. To replace worn gear, remove angle bracket, item 5, 2 screws, item 6, from Cutting Torch Block Assembly.
4. Worn gear replacement is identical in procedure to rack block as stated under Rack Block Adjustments.

RACK ASSEMBLIES

(See Page 19)

1. The standard Rack Assembly has one tube plug, item 2, secured with pin, item 3.

2. Rack Assemblies included in Pack Rat II Systems or Standard Racking Assemblies will be shipped with a safety retainer installed, which will prevent the removal of Rack Assemblies and should be utilized for all non-horizontal racking applications.

CAUTION: Please Read Safety Regulations Carefully.
(See Page 3)

CABLE STRAIN RELIEF

(See Page 18)

1. Cable Strain Relief has been designed to accommodate various diameters of cable. To enlarge capacity, remove knob, item 2, and reinsert clamp in slot needed on item 3.
2. To swivel clamp, loosen clamping screw in swivel block, item 4, and relocate.
3. The Strain Relief can be mounted in various positions on the Travel Carriage, using mounting bolts, item 7. (See page 5 for mounting hole layout.)

OPERATION

CONTROL BOX

(See Page 15)

1. The Pack Rat II Travel Carriage is operated by the main ON/OFF switch, item 4, for starting and stopping. (Up - START, Down - STOP)
2. The direction of travel is controlled by the Forward/Reverse switch, item 3, and the direction may be changed while in motion.
3. A potentiometer, item 15, controls the travel speed. The inches per minute meter is approximate. (Note: Repeatability is $\pm 5\%$ of total scale.) Speed variation for all three ranges provided is less than $\pm 3\%$ of the full speed value over the specified control ranges, when used in the vertical travel mode with a 50 lb. load. All horizontal loadings will have less variation than the vertical position, because of the more constant load presented to the motor/gear box.
4. The meter assembly includes a small potentiometer. This potentiometer and the three potentiometers included on the speed control assembly are preset at the factory. These potentiometers are protected against vibration with a small amount of "glyptol".

ACCESS TO CONTROL BOX WIRING

Access to wiring is achieved by removing one screw, item 2. Lid hinges away from screw removed. Disengage two tabs located on lid, item 26, from lower chassis for complete disassembly.

NOTE: Service length wires have been provided on components connecting lid to chassis. Excessive working of these wires may result in damaged leads.

ACCESSORY OUTLET CONNECTION

(See Page 15, Item 31)

An Accessory 115 VAC Outlet is provided to operate as:

- A. Continuously hot (as delivered from factory)
- B. Switched by the main ON/OFF switch
- C. Switched by the main and/or the limit switch if used)

TROUBLE SHOOTING

PROBLEM: Blown Fuses

1. Excessive Motor/Gear Box Load

Check condition of pinion and rack, i.e., spatter, broken teeth, etc. Verify motor/gear box pinion to track rack adjustment. (See page 6 for proper alignment instructions.)

2. Worn Brushes

3. Speed Control Failure

When inoperative, remove speed control and replace.

4. Short in Electrical Circuit

MAINTENANCE

1. Maintenance of the Pack Rat II System will normally consist of a general cleaning of all moving parts and their mating surfaces, at regular intervals.

2. The only parts on the Pack Rat II System that are subject to normal wear are the travel carriage wheels, track, rack assemblies, motor/gear box

pinion gear, rack block gears and heat shields. A supply of these parts should be maintained on hand.

3. If repairs do become necessary, any part can easily be replaced by a qualified shop maintenance man.

SAFETY PRECAUTIONS

Virtually every occupation has certain potential hazards. This is just as true of Pack Rat II Travel Carriage System used in conjunction with torch cutting, MIG welding, etc. Operators should be aware

of the potential hazards and observe the necessary precautions before attempting to operate the Travel Carriage or its accessories.

NOTE: See Safety Regulations, Page 3 For Specific Details.

FEATURES

DWG. NO. 097-0021

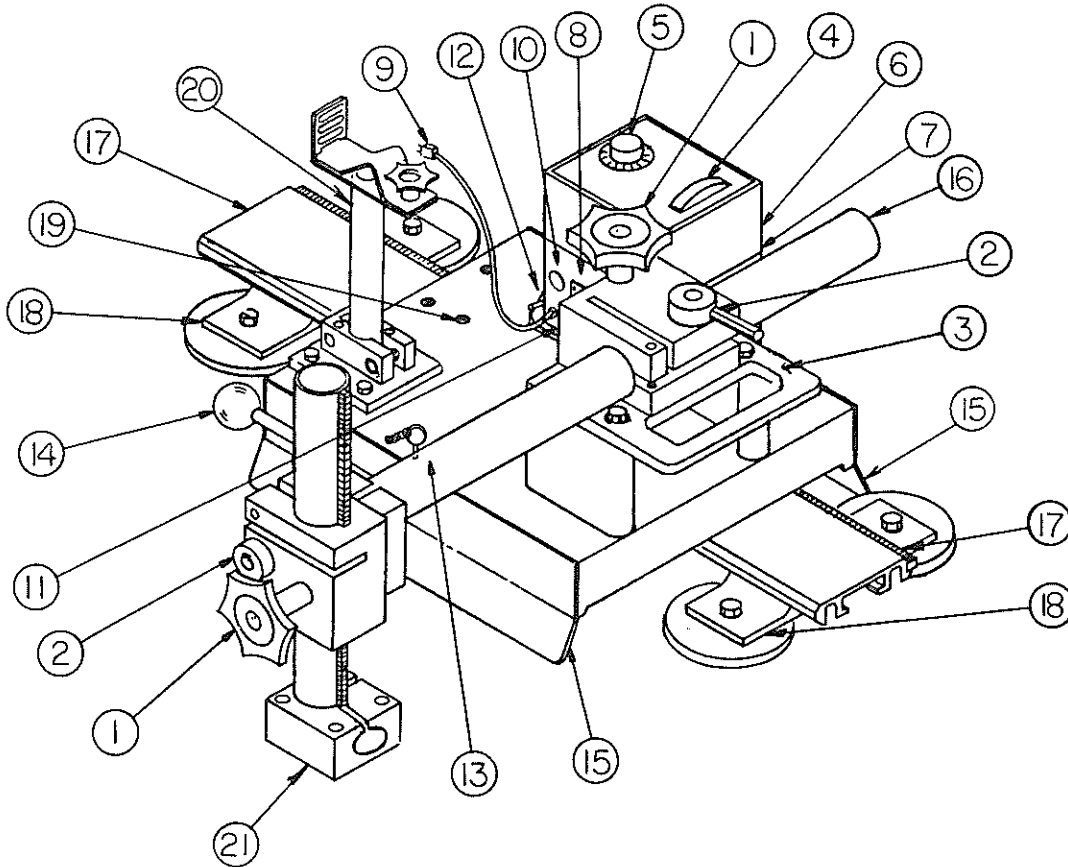

ITEM NO.	DESCRIPTION	ITEM NO.	DESCRIPTION
1.	Racking Adjustment Knob	11.	2 Amp Fuse
2.	Racking Tension Adjustment Lever	12.	Control Box Cam Locking Handle
3.	Handle	13.	Cam Lock Safety Chain
4.	IPM Indicator "Meter"	14.	Tractor Plate Cam Locking Handle
5.	IPM Control Knob	15.	Heat Shield
6.	Forward/Reverse Switch	16.	Racking Assembly
7.	On/Off Switch	17.	Track Assembly
8.	110 Vac Accessory Outlet	18.	Mounting Bracket
9.	110 Vac Cord	19.	Access Holes for Mounting Additional Racking or Accessories
10.	Electrical Accessory Access Button	20.	Cable Strain Relief
		21.	Clamp Block

PACK RAT II SINGLE CUTTING TORCH SYSTEM

DWG. NO. 097-0022

MODEL NOS.

128 - 211 0 To 6 I.P.M. (0 To 15cm/min)
 128 - 221 3.0 To 60 I.P.M. (7.6 To 150cm/min)
 128 - 231 18.0 To 180 I.P.M. (45 To 450cm/min)

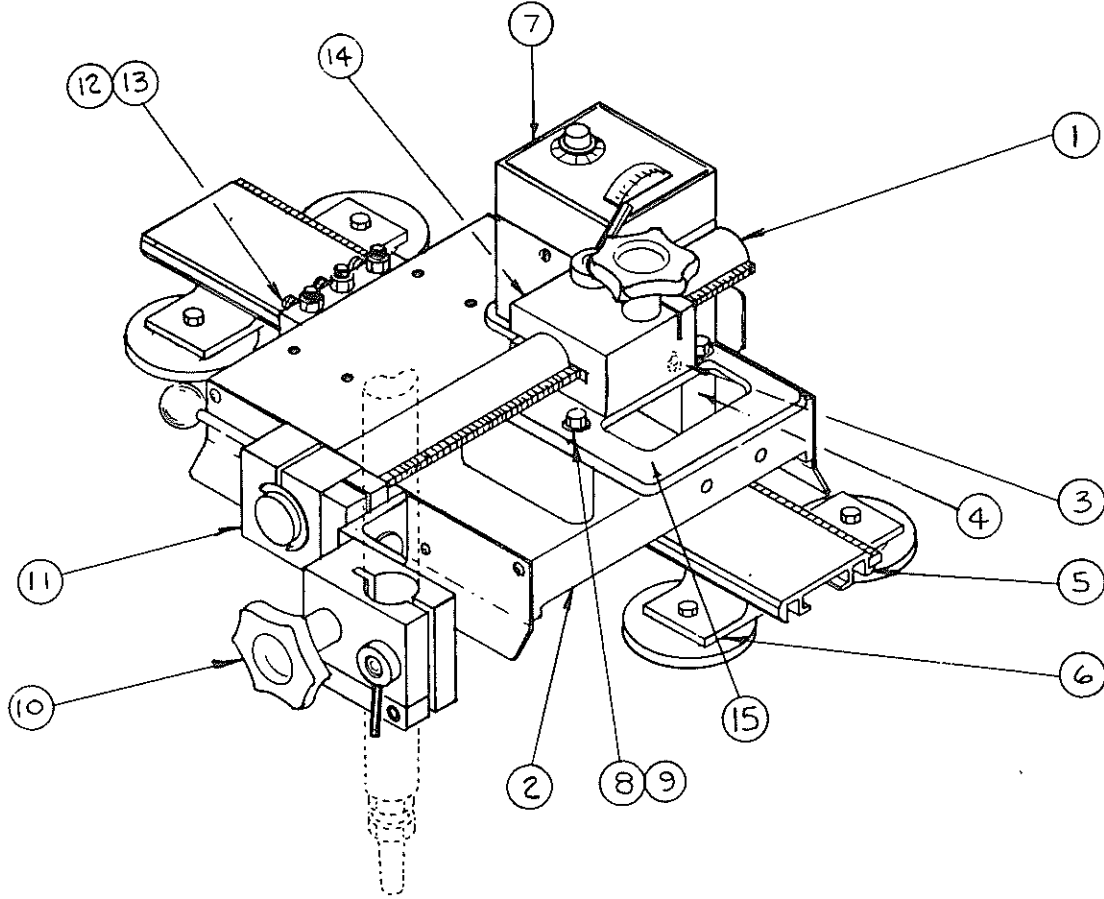

ITEM	PART NO.	QTY.	DESCRIPTION	ITEM	PART NO.	QTY.	DESCRIPTION
1.	003-0600	1	12 in. (305mm) Rack Assembly	7.	003-1618	1	18.0 To 180 IPM (45 To 450cm/mm) Control Box
2.	003-1610	1	Tractor Plate Assembly	8.	329-0216	4	Hx Hd Blt, 3/8-16 x 4"
3.	328-0055	4	Soc Hd Cap Scr 1/4-20 x 3/8"	9.	331-0100	4	Flat Wshr 3/8"
4.	431-2009	2	3 in. (76mm) Riser Block	10.	003-1602	1	Cutting Torch Holder
5.	001-0624	1	6 ft. (180cm) Standard Track Assembly	11.	003-0032	1	Clamp Block
6.	001-0359	2	3 in. (76mm) Standard Magnetic Mounting Bracket	12.	003-1603	1	Gas Manifold
7.	003-1609	1	0 To 6 IPM (0 To 15cm/mm) Control Box	13.	328-0060	2	Soc Hd Cap Scr 1/4-20 x 1"
7.	003-1612	1	3.0 To 60 IPM (7.6 To 150cm/mm) Control Box	14.	003-1604	1	Rack Block
				15.	435-0555	1	Base Plate With Handle

PACK RAT II DUAL CUTTING TORCH SYSTEM

DWG. NO. 097-0023

MODEL NOS.

128 - 212 0 To 6 I.P.M. (0 To 15cm/min)
 128 - 222 3.0 To 60 I.P.M. (7.6 To 150cm/min)
 128 - 232 18.0 To 180 I.P.M. (45 To 450cm/min)

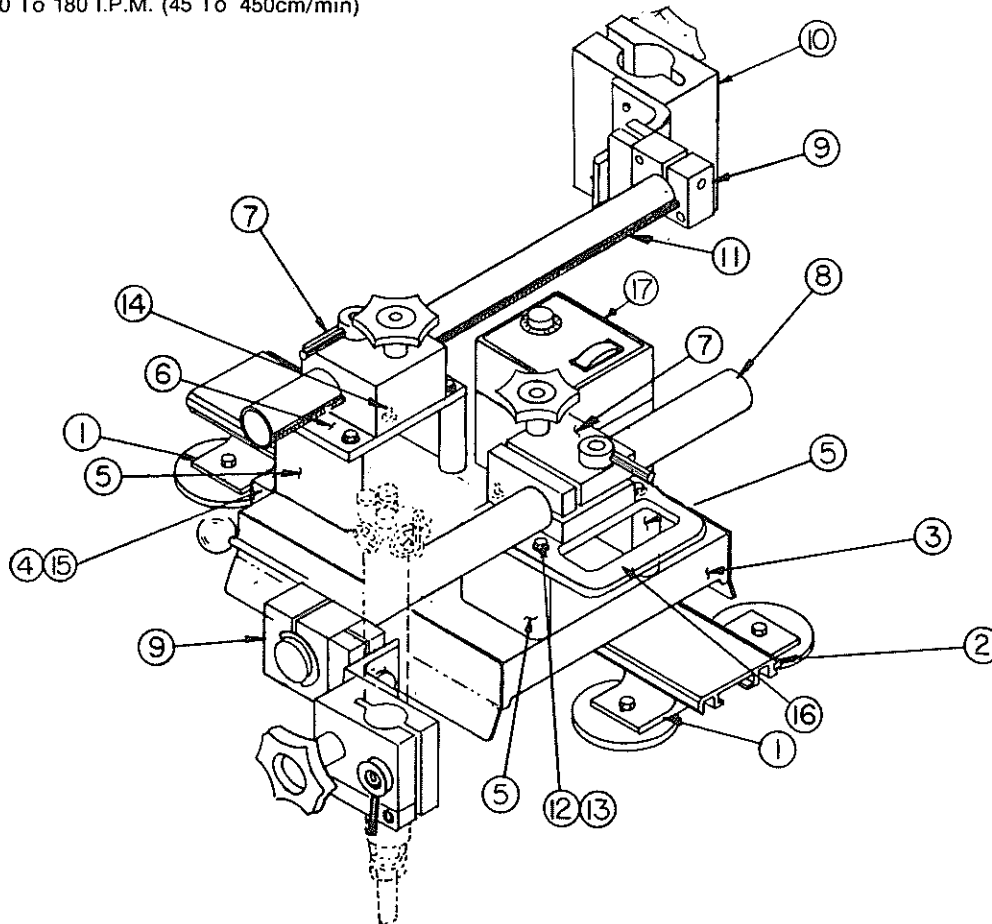

ITEM	PART NO.	QTY.	DESCRIPTION	ITEM	PART NO.	QTY.	DESCRIPTION
1.	001-0359	2	3 in. (76mm) Standard Magnetic Mounting Bracket	11.	003-0606	1	18 in. (457mm) Rack Assembly
2.	001-0624	1	6 ft. (180cm) Standard Track Assembly	12.	329-0216	8	Hx Hd Bit 3/8-16 x 4"
3.	003-1610	1	Tractor Plate Assembly	13.	331-0100	8	Flat Wshr 3/8"
4.	003-1603	1	Gas Manifold	14.	328-0055	8	Soc Hd Cap Scr 1/4-20 x 3/8"
5.	431-2009	4	3 in. (76mm) Riser Block	15.	328-0060	2	Soc Hd Cap Scr 1/4-20 x 1"
6.	435-0251	1	Base Plate	16.	435-0555	1	Base Plate With Handle
7.	003-1604	2	Rack Block	17.	003-1609	1	0 To 6 IPM (0 To 15cm/mm) Control Box
8.	003-0600	1	12 in. (305mm) Rack Assembly	17.	003-1612	1	3.0 To 60 IPM (7.6 To 150cm/mm) Control Box
9.	003-0032	2	Clamp Block	17.	003-1618	1	18.0 To 180 IPM (45 To 450cm/mm) Control Box
10.	003-1602	2	Cutting Torch Holder				

PACK RAT II COBRA/ UNIVERSAL MIG SYSTEM

DWG. NO. 097-0024

MODEL NOS.

128 - 216 0 To 6 I.P.M. (0 To 15cm/min)
 128 - 226 3.0 To 60 I.P.M. (7.6 To 150cm/min)
 128 - 236 18.0 To 180 I.P.M. (45 To 450cm/min)

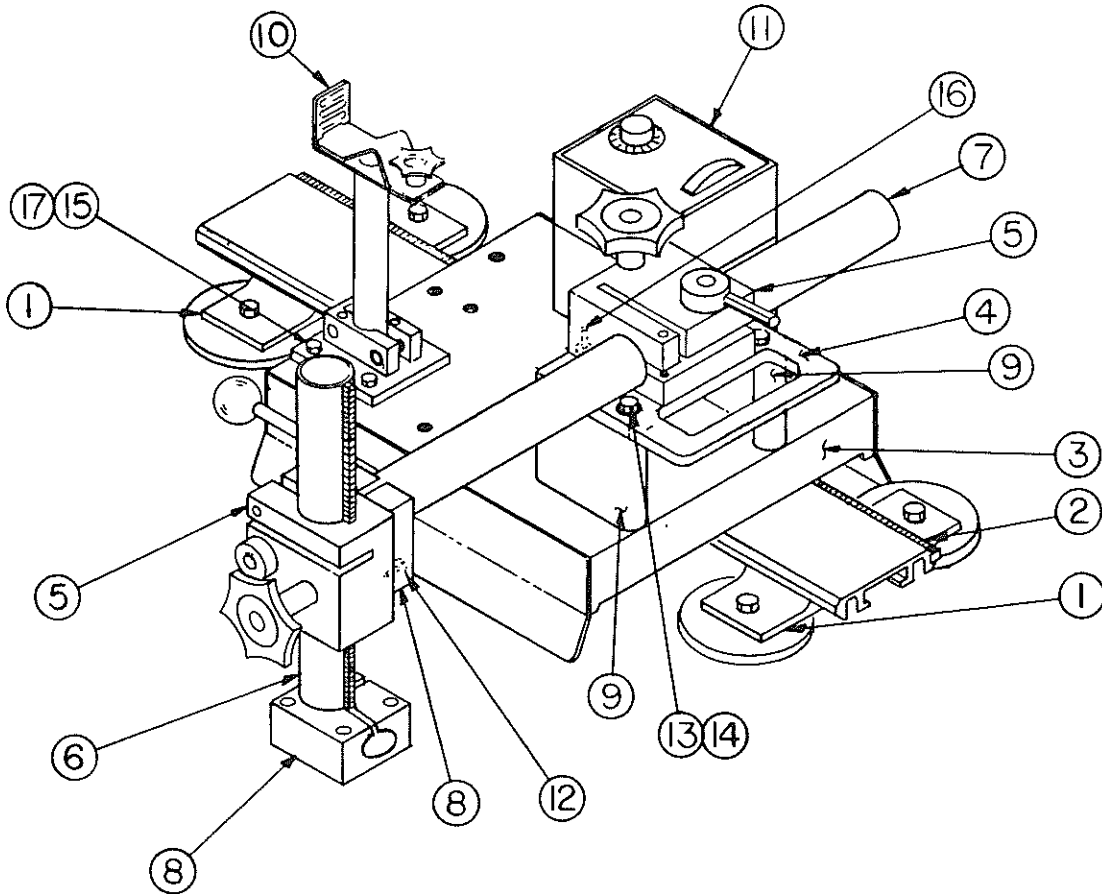

ITEM	PART NO.	QTY.	DESCRIPTION	ITEM	PART NO.	QTY.	DESCRIPTION
1.	001-0359	2	3 in. (76mm) Standard Magnetic Mounting Bracket	11.	003-1609	1	0 To 6 IPM (0 To 15cm/mm) Control Box
2.	001-0624	1	6 ft. (180cm) Standard Track Assembly	11.	003-1612	1	3.0 To 60 IPM (7.6 To 150cm/mm) Control Box
3.	003-1610	1	Tractor Plate Assembly	11.	003-1618	1	18.0 To 180 IPM (45 To 450cm/mm) Control Box
4.	435-0555	1	Base Plate With Handle	12.	328-0061	2	Soc Hd Cap Scr 1/4-20 x 1-1/4"
5.	003-1604	2	Rack Block	13.	329-0216	4	Hx Hd Bit 3/8-16 x 4"
6.	003-0600	1	12 in. (305mm) Rack Assembly	14.	331-0100	4	Flat Wshr 3/8"
7.	003-0606	1	18 in. (457mm) Rack Assembly	15.	329-0056	2	Hx Hd Cap Scr 3/8-16 x 7/8"
8.	003-0032	2	Clamp Block	16.	328-0055	4	Soc Hd Cap Scr 1/4-20 x 3/8"
9.	431-2009	2	3 in. (76mm) Riser Block	17.	331-0006	2	Plain Wshr 3/16"
10.	001-0595	1	Cable Strain Relief Assembly				

PACK RAT II WIGGLER/COBRAMATIC SYSTEM

DWG. NO. 097-0025

MODEL NOS.

128 - 215 0 To 6 I.P.M. (0 To 15cm/min)
128 - 225 3.0 To 60 I.P.M. (7.6 To 150cm/min)

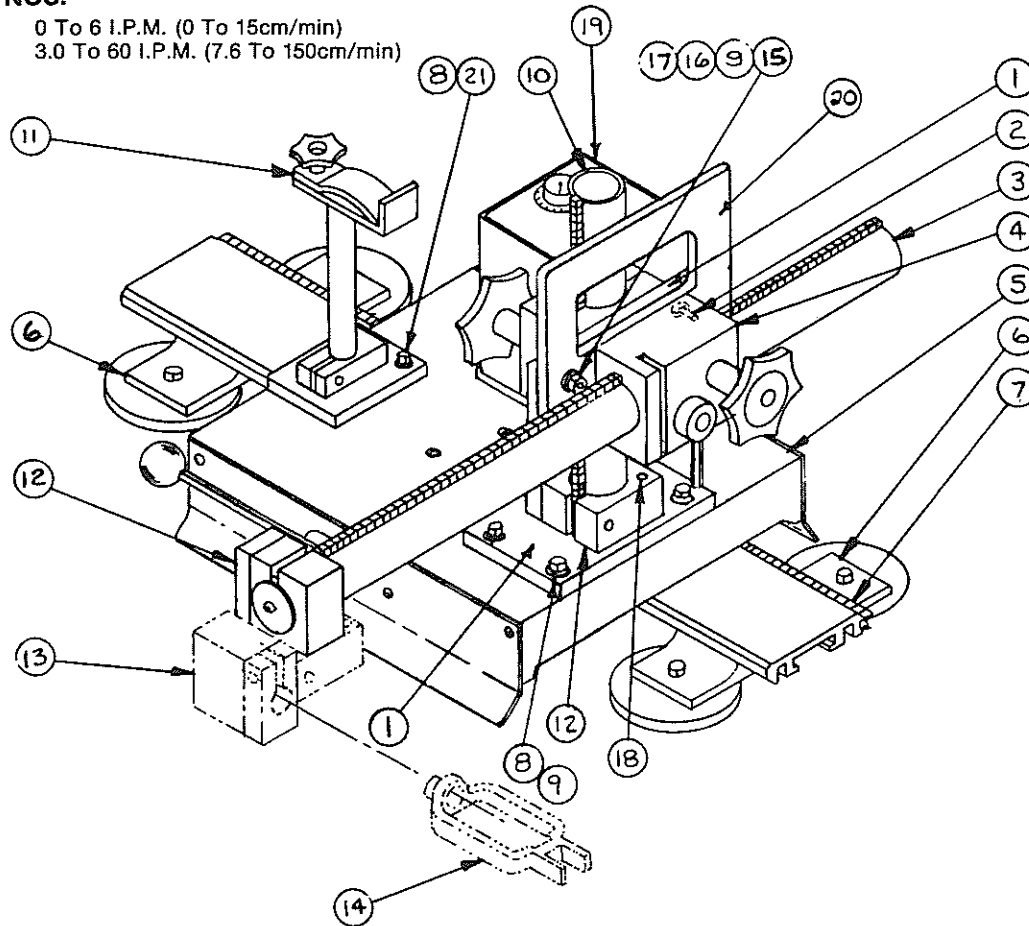

ITEM	PART NO.	QTY.	DESCRIPTION	ITEM	PART NO.	QTY.	DESCRIPTION
1.	435-0251	2	Base Plate	13.	005-0063	1	Multi-Direction Block(Optional)
2.	328-0055	8	Soc Hd Cap Scr 1/4-20 x 3/8"	14.	003-0105	1	Wiggler Mounting Bracket(Optional)
3.	003-0606	1	18 in. (457mm) Rack Assembly	15.	333-0011	4	Lock Wshr 3/8"
4.	003-1604	2	Rack Block	16.	341-0014	4	Hx Nut 3/8-16
5.	003-1610	1	Tractor Plate Assembly	17.	329-0059	4	Hx Hd Cap Scr 3/8-16 x 1-1/2"
6.	001-0359	2	3 in. (76mm) Standard Magnetic Mounting Bracket	18.	328-0061	2	Soc Hd Cap Scr 1/4-20 x 1-1/4"
7.	001-0624	1	6 ft. (180cm) Standard Track Assembly	19.	003-1609	1	0 To 6 IPM (0 To 15cm/mm) Control Box
8.	329-0056	6	Hx Hd Cap Scr 3/8-16 x 7/8"	19.	003-1612	1	3.0 To 60 IPM (7.6 To 150cm/mm) Control Box
9.	331-0006	12	Plain Wshr 5/16"	19.	003-1618	1	18.0 To 180 IPM (45 To 450cm/mm) Control Box
10.	003-0600	1	12 in. (305mm) Rack Assembly	20.	435-0555	1	Base Plate With Handle
11.	001-0595	1	Cable Strain Relief Assembly	21.	331-0029	2	Flat Washer
12.	003-0032	2	Clamp Block				

PACK RAT II TRAVEL CARRIAGE

DWG. NO. 097-0026

TRAVEL CARRIAGE ASSEMBLY PART NUMBER 003-1610

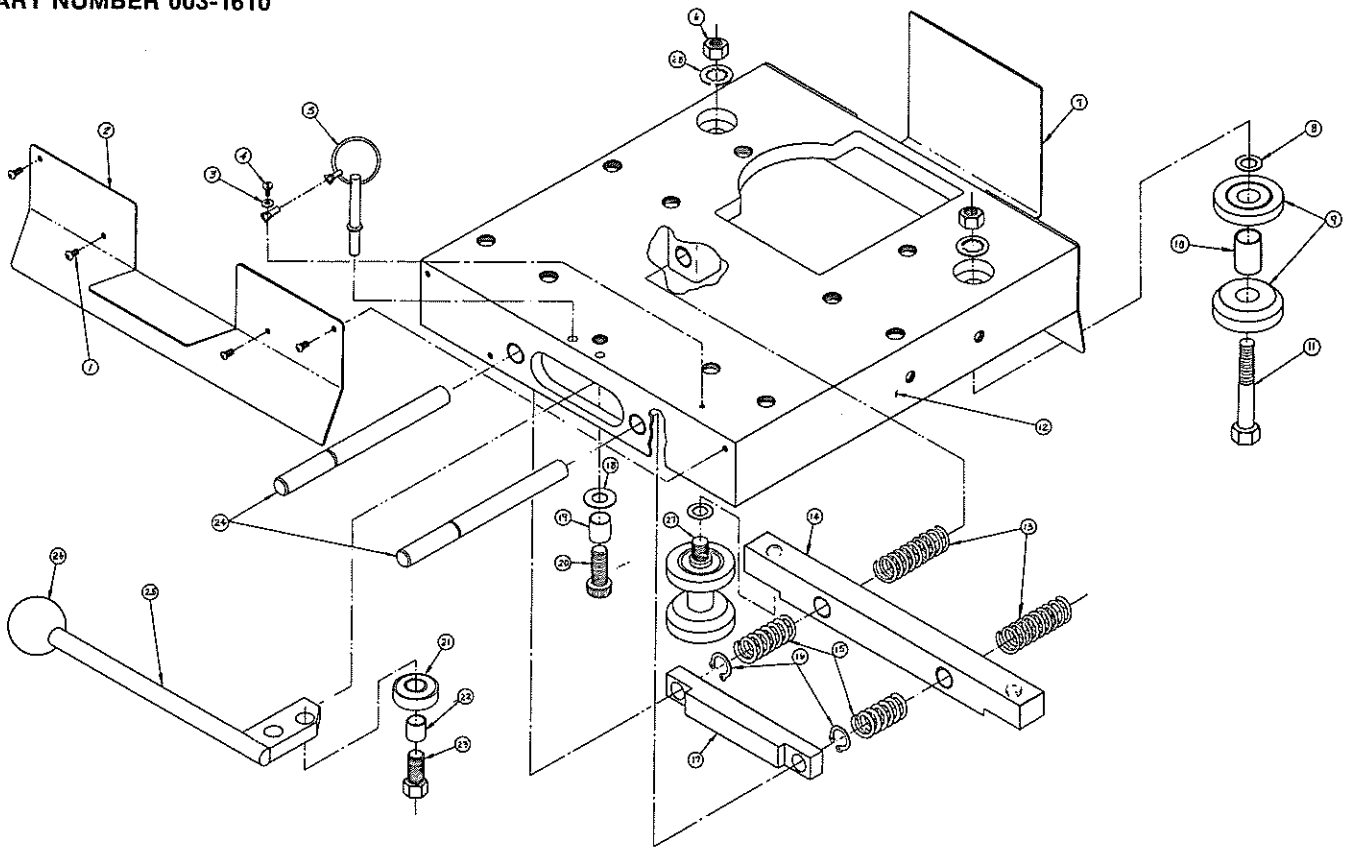

ITEM	PART NO.	QTY.	DESCRIPTION	ITEM	PART NO.	QTY.	DESCRIPTION
1.	320-0009	8	Button Hd Scr 8-32 x 3/8"	15.	419-0003	2	Comp. Die Spr.-Clamping
2.	435-0467		Heat Spatter Shield Cam Lever	16.	313-0011	2	E-Ring 3/8" I.D.
3.	331-0019		#4 Wshr Flat Std Steel	17.	431-1016		Thrust Bar 5/8" x 3/4"
4.	325-0067		Pn Hd Scr 4-40 x 1/4" lg.	18.	331-0025		Wshr, Flat Steel 5/16"
5.	003-0605		Release Pin	19.	342-0066		Spacer 5/16" I.D. x 3/8" O.D. x .265
6.	341-0014	2	Nut Hx 3/8-16 Stl/Cad	20.	328-0086		Scr Shc 5/16-18 x 3/4"
7.	435-0466		Heat Spatter Shield, Control Box	21.	501-0156		Bearing, Ball
8.	331-0046	4	Wshr Flt, 3/8" I.D. x 5/8" O.D.	22.	342-0067		Spacer 1/4" I.D. x 3/8" O.D. x .287
9.	515-0003	8	Assy. Wheel	23.	329-0001		Scr Hx 2 1/4-20 x 1/2"
10.	342-0030	4	Spacer, Wheel 3/8" I.D. x 1/2" O.D.	24.	505-0037	2	Shaft, Tractor 3/8" Dia.
11.	329-0218	2	Scr Hx 3/8-16 x 2 1/2"	25.	002-0242		S/A Tractor Cam/Handle
12.	431-2008		Tractor Plate	26.	401-0017		Knob Ball, Plastic
13.	419-0010	2	Comp. Spr.-Return	27.	329-0217	2	Scr Hx 3/8-16 x 2"
14.	431-1017		Clamping Bar	28.	333-0049	2	Wshr Lock, 3/8" Int Star

PACK RAT II CONTROL BOX

DWG. NO. 097-0027

CONTROL BOX PART NUMBERS:

003 - 1609	0 To 6 I.P.M. (0 To 15cm/min)
003 - 1612	3.0 To 60 I.P.M. (7.6 To 150cm/min)
003 - 1618	18.0 To 180 I.P.M. (45 To 450cm/min)

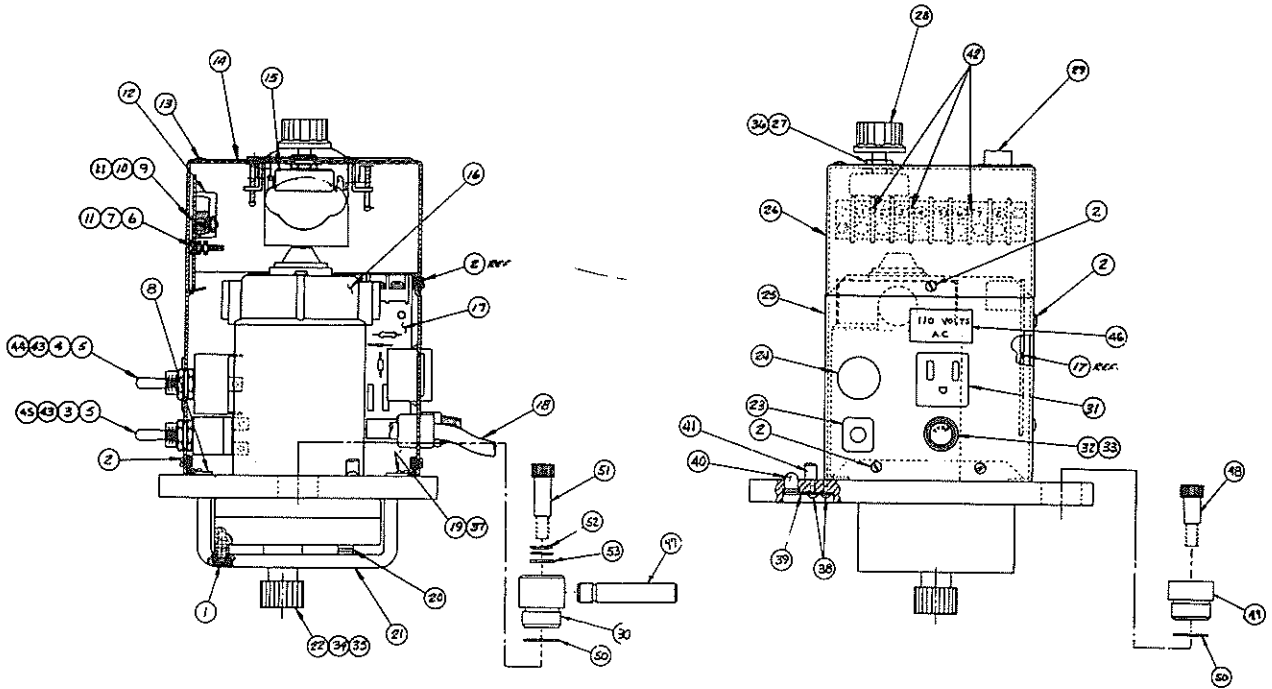

ITEM	PART NO.	QTY.	DESCRIPTION	ITEM	PART NO.	QTY.	DESCRIPTION
1.	328-0045	4	Sh Scr 10-32 x 3/8"	26.	002-0240		W/A Control Box Lid
2.	325-0067	9	Scr Pn Hd 4-40 x 1/4"	27.	341-0050	2	Nut Hx 3/8-32
3.	003-0094		Rev. Swx. S/A Wiring	28.	401-0012		Knob 1 in. Dia. Blk.
4.	003-0097		On/Off Swx. S/A Wiring	29.	003-0617		S/A Meter w/Leads 0-6 IPM
5.	341-0054	4	Nut Hx 15/32-32BRS/NKL	29.	003-0613		S/A Meter w/Leads 3-60 IPM
6.	324-0135		Scr FHSM 6-32 x 1/2"	29.	003-0615		S/A Meter w/Leads 18-180 IPM
7.	333-0024		Wshr Lock 8 Ext Star	30.	431-0595		Eccentric Gear Disconnect
8.	435-1460	2	Bracket Mtg. C. Box	31.	003-0216		S/A Conn. Wired 153-0297
9.	324-0134	2	Screw FHMS 6-32 x 7/16"	32.	003-0096		Fuseholder S/A Wiring
10.	333-0023	2	Wshr Lock 6 Ext. Star	33.	151-0010		Fuse MDL 2A
11.	341-0005	2	Nut Hx 6-32 STL/Cad	34.	321-0026		Scr Cps 6-32 x 1/8"
12.	186-0014		Term. Strip 8 Connector	35.	421-0004		Key Woodruff, 2-3/32 x 1/2"
13.	305-0004	4	Pop Rivet 1/8 / .06 / .12 GP AL	36.	333-0156		Wshr Lock, 3/8" Int Star
14.	405-0131		Name Plate	37.	333-0005	4	Wshr Lock, 6 Spring
15.	003-0614		S/A Pot 10 in. Lead PR II	38.	320-0001	2	Scr BHSC, 4-40 x 1/4"
16.	211-0037		Gear Motor, 1471:1 w/Term. 0 To 6 IPM	39.	419-0035		Spr Flat Strip
16.	211-0027		Gear Motor, 96:1 w/Term. 3.0 To 60 IPM	40.	431-1003		Pin Indent Ecc. Lock
16.	211-0030		Gear Motor, 48:1 w/Term. 18-180 IPM	41.	421-0042		Dowel Pin 1/4 x 1" lg.
17.	179-0016		Speed Ctrl 115V/90VDC PM	42.	186-0223	3	Term. Jumper 2 Contacts
18.	843-0062		S/A Cable Power AC	43.	333-0154	2	Wshr. Lock 15/32 Int. Star
19.	325-0131	4	Scr Ph 6-32 x 1/4"	44.	405-0005		Plate On-Off Swx
20.	342-0068	4	Spacer, Mod. .192-0069	45.	405-0132		Swx. Plate Fwd./Rev.
25.	002-0241		W/A Control Box	46.	921-0124		Decal Aux. 115 VAC H
21.	431-1015		Holder Mtr. Mach. Cast. PR II	47.	415-0020		Handle Eccentric
22.	507-0099		Spur Gear 20P-14T-.70PD	48.	330-0009		Screw Shdr 5/16 x 1/2"
23.	315-0696		Bushing Strain Relief	49.	431-0570		Eccentric
24.	351-0038		Plug 5/8 in. Snap Button	50.	331-0195		Wshr Flat .26 x .38 x .03 STL
				51.	330-0012		Screw Shdr 5/16 x 1"
				52.	333-0161		Wshr Wave Shape Sprg
				53.	342-0070		Spacer Eccentric .312 I.D. x .44 O.D.

PARTS LIST

TRAVEL CARRIAGE ASSEMBLY

P/N SEE BELOW

USED IN CONJUNCTION WITH ALL RACKING ASSEMBLIES.

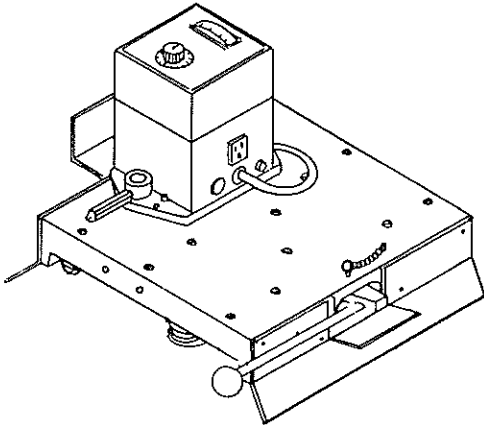

0 To 6 I.P.M. (0 To 15 cm/min) - P/N 003-1605
3.0 To 60 I.P.M. (7.6 To 150 cm/min) - P/N 003-1606
18.0 To 180 I.P.M. (45 To 450 cm/min) - P/N 003-1607

CONTROL BOX ASSEMBLY

P/N SEE BELOW

MUST BE USED WITH TRACTOR PLATE ASSEMBLY
P/N 003-1610.

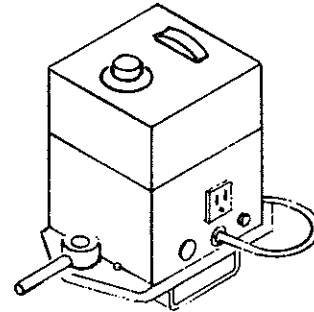

0 To 6 I.P.M. (0 To 15 cm/min) - P/N 003-1609
3.0 To 60 I.P.M. (7.6 To 150 cm/min) - P/N 003-1612
18.0 To 180 I.P.M. (45 To 450 cm/min) - P/N 003-1618

TRACTOR PLATE ASSEMBLY

P/N 003-1610

MAY BE USED WITH A CONTROL BOX AND RACKING
ASSEMBLY OR AS A TRAILER ASSEMBLY WITH TRAILER
HITCH P/N 431-0686.

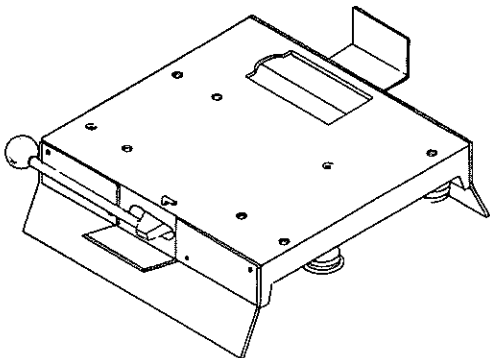

SINGLE CUTTING TORCH SYSTEM RACKING ASSEMBLY

P/N 003-1611

INCLUDES MOUNTING HARDWARE.

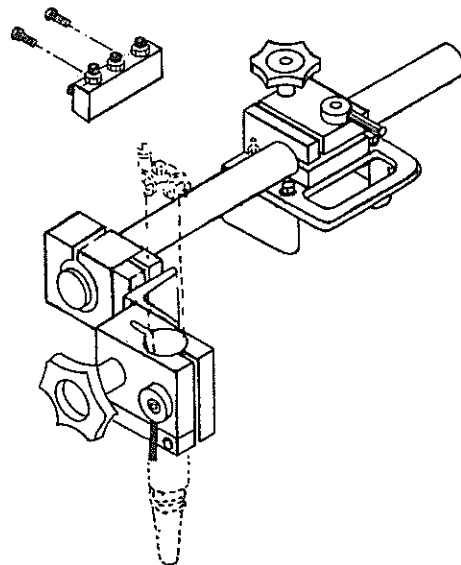

PARTS LIST

DUAL CUTTING TORCH SYSTEM RACKING ASSEMBLY

P/N 003-0201

INCLUDES MOUNTING HARDWARE.

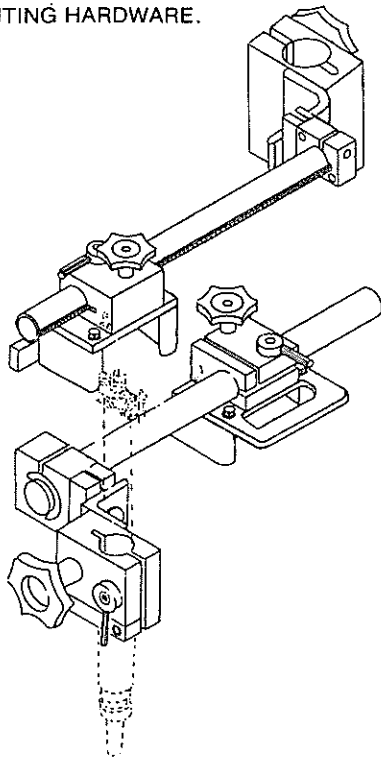

COBRA/UNIVERSAL MIG SYSTEM RACKING ASSEMBLY

P/N 003-0202

INCLUDES MOUNTING HARDWARE.

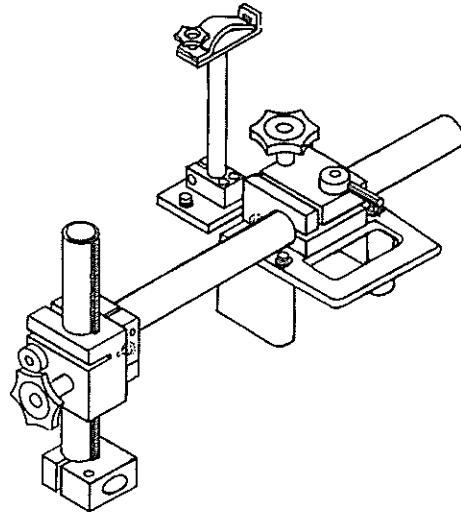

WIGGLER/COBRAMATIC MIG SYSTEM RACKING ASSEMBLY

P/N 005-0075

INCLUDES MOUNTING HARDWARE.

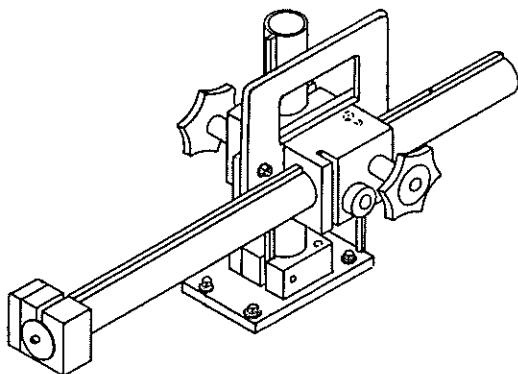

GAS MANIFOLD ASSEMBLY

P/N 003-1603

FOR USE WITH 2 OR 3 HOSE TORCHES.

ALSO USED WITH OPTIONAL CUTTING SOLENOID ASSEMBLY P/N 003-0230.

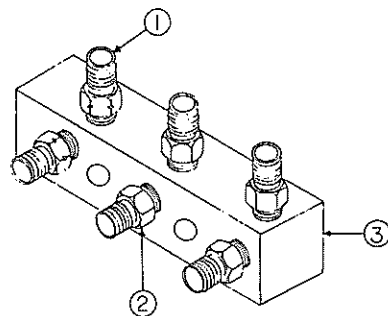

1. Acet. Fitting 1/4" NPT To 9/16"-P/N 753-0030 (2)
2. Oxy. Fitting 1/4" NPT To 9/16"-P/N 753-0023 (4)

3. Gas Manifold Block-P/N 431-1025
Not Shown
4. Cap Plug 1/2" x 7/8" SC-P/N 751-0006 (6)

PARTS LIST

CABLE STRAIN RELIEF ASSEMBLY

P/N 001-0595

FOR USE WITH ALL MIG PACK RAT SYSTEMS.
THIS ASSEMBLY MOUNTS ON THE TRAVEL CARRIAGE
USING EXISTING HOLES.

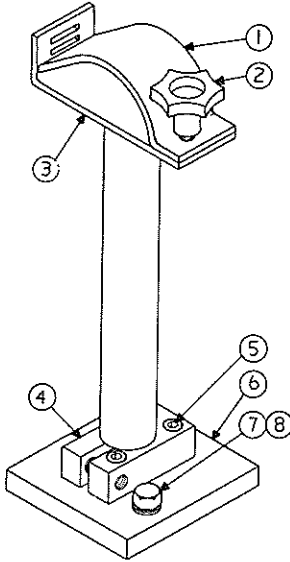

1. Clamp-Strain Relief-P/N 435-0359
2. Knob-Modified-P/N 401-0008
3. Bracket-Strain Relief-P/N 002-0135
4. Block-Swivel Extension-P/N 431-0551
5. Soc Hd Cap Scr 10-24 x 3/4" lg.- P/N 328-0038 (3)
6. Cable Strain Relief Mtg. Plate-P/N 435-0360
7. Hx Hd Cap Scr 3/8-16 x 7/8"- P/N 329-0056 (2)
8. Flat Wshr Steel-P/N 331-0029 (2)

NOTE: Items 1, 2, & 3 are available as an assembly P/N 003-0114. This assembly may be mounted at the end of a rack assembly using a Clamp Block-P/N 003-0032. This will enable the Cable Strain Relief Assembly to be racked.

RISER BLOCKS - 3" (76mm)

P/N 431-2009

TWO REQUIRED TO RAISE EACH BASE PLATE AND RACK BLOCK.

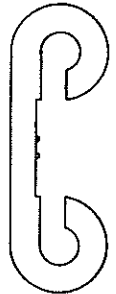
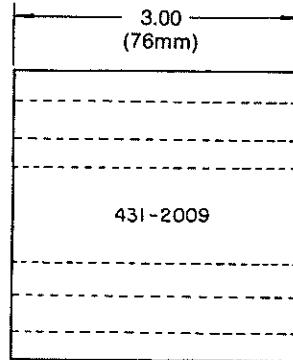

BASE PLATE

P/N 435-0251

USED TO MOUNT CLAMP BLOCKS, RACK BLOCKS, AND RISER BLOCKS. ALSO USED WHEN ASSEMBLING TWO RACK BLOCKS TOGETHER.

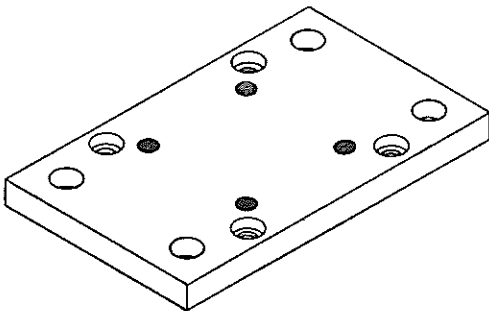

BASE PLATE WITH HANDLE

P/N 435-0555

USED TO MOUNT CLAMP BLOCKS, RACK BLOCKS, AND RISER BLOCKS. ALSO USED WHEN ASSEMBLING TWO RACK BLOCKS TOGETHER.

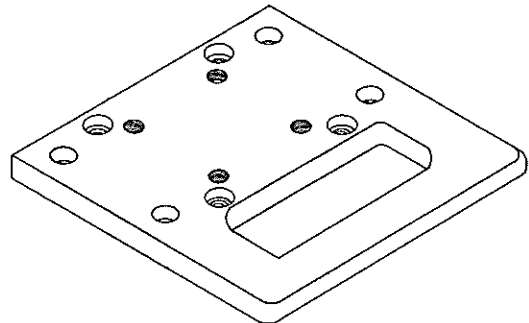

PARTS LIST

RACK BLOCK P/N 003-1604

USE WITH RACK ASSEMBLIES PART NUMBERS:
12" (305mm)-P/N 003-0600
18" (457mm)-P/N 003-0606
24" (610mm)-P/N 003-0607

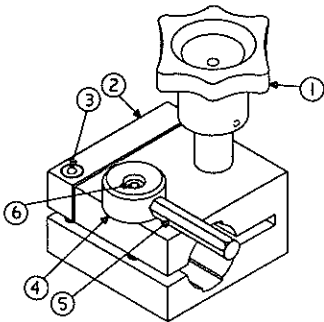

- | | |
|--|---|
| 1. Shaft/Handle Assy. Clamp Block-
P/N 401-0024 | 7. E Ring 1/4" Int. Dia.-P/N 313-0012 |
| 2. Rack Block Universal-P/N
431-1027 | 8. Wshr Flat Brass-P/N 331-0173 |
| 3. Soc Hd Cap Scr 1/4-20 x 1 1/4"-
P/N 328-0061 | 9. Helicoil 1/4-20 x 3/8"-P/N 351-
0011 (6) |
| 4. Body Clamp Adjustment Block-
P/N 431-1021 | 10. Helicoil 1/4-20 x 5/8"-P/N 351-
0042 (2) |
| 5. Handle Clamp Adjustment Block-
P/N 431-1022 | 11. Bearing Flanged 1/4" I.D.-P/N
501-0043 |
| 6. Soc Hd Cap Scr 1/4-20 x 1 3/4"-
P/N 328-0063 | 12. Bearing Flanged 5/16" I.D.-
P/N 501-0054 |
| | 13. Gear Pinion 24 Pitch-P/N
507-0133 |

Not Shown

RACK ASSEMBLY

P/N 003-0600 12" (305mm)
P/N 003-0606 18" (457mm)
P/N 003-0607 24" (610mm)

USE WITH RACK BLOCK
P/N 003-1604 AND CLAMP
BLOCK P/N 003-0032.

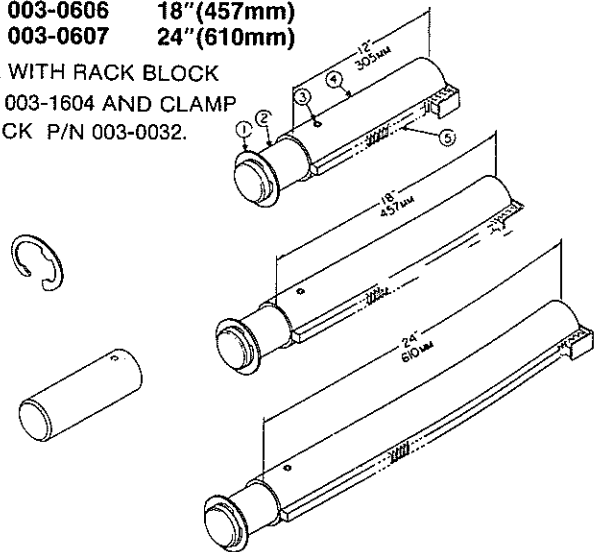

- | | |
|---|---|
| 1. E Ring 822 Int Dia.-P/N 313-0015 | 5. 12" (305mm) Gear Rack-P/N
507-0071 |
| 2. Plug Rack Tube PR II-P/N 431-
1014 | 5. 18" (457mm) Gear Rack-P/N
507-0076 |
| 3. Spring Pin 3/16" x 1/2"-P/N 421-
0213 | 5. 24" (610mm) Gear Rack-P/N
507-0070 |
| 4. 12" (305mm) Rack Carrier-P/N
431-1010 | Not Shown |
| 4. 18" (457mm) Rack Carrier-P/N
431-1011 | 6. Gear Rack Retaining Scr 6-40 x
1/4" Soc Hd Cap Scr-P/N 328-
0018 |
| 4. 24" (610mm) Rack Carrier-P/N
431-1012 | 7. #6 Lock Wshr For Above-P/N
333-0005 (2 Req'd Per Scr) |

CLAMP BLOCK P/N 003-0032

USED TO MOUNT ALL TORCH HOLDERS.

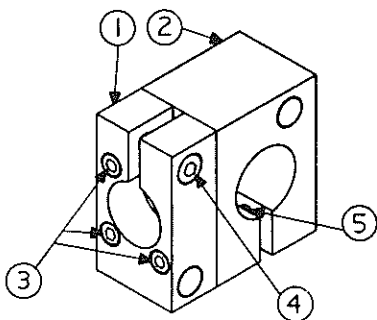

- | | |
|---|--|
| 1. Block Swivel Extension-P/N
431-0551 | 4. Soc Hd Cap Scr 1/4-20 x 3/4"-
P/N 328-0058 |
| 2. Block Swivel Adapter-P/N
431-0550 | 5. Soc Hd Cap Scr 1/4-20 x 1 1/4"-
P/N 328-0061 |
| 3. Soc Hd Cap Scr 10-24 x 3/4"-
P/N 328-0038 (3) | |

CUTTING TORCH HOLDER P/N 003-1602

USE WITH STANDARD MACHINE CUTTING TORCH W/1.38" (35mm) DIA. AND 32 PITCH RACK. MUST BE USED WITH CLAMP BLOCK P/N 003-0032.*

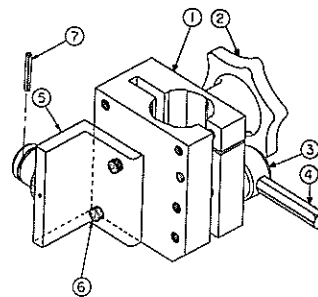

- | | |
|---|--|
| 1. Torch Block-P/N 431-1026 | 9. Screw Shc 1/4-20 x 1 1/4"-
P/N 328-0061 |
| 2. Sht/Handle Assy Clamp Bick-
P/N 401-0024 | 10. Screw Shc 1/4-20 x 1 3/4"-
P/N 328-0063 |
| 3. Body Clamp Adjust Bick Pr-
P/N 431-1021 | 11. Wshr, Flat Brass .28 x .75 -
P/N 331-0173 |
| 4. Handle Clp Adjustment Bick-
P/N 431-1022 | 12. Helicoil, 1/4 x 20 x 3/8"-
P/N 351-0011 (6) |
| 5. Mtg. Angle S/A Swvel Plug-
P/N 003-1226 | 13. Helicoil, 1/4 x 20 x 5/8"-
P/N 351-0042 (2) |
| 6. Screw Shc 1/4-20 x 3/4"-
P/N 328-0058 (2) | 14. Bearing, Flanged 1/4" I.D.-
P/N 501-0043 |
| 7. Spr. Pin 3/32" x 1 1/8"-
P/N 421-0170 | 15. Bearing, Flanged 5/16" I.D.-
P/N 501-0054 |
| Not Shown | 16. Pinion Gr Torch Adj.-
P/N 507-0132 |
| 8. E-Ring 1/4" Int.Dia.-P/N
313-0012 | |

*NOTE: For Cutting Torch Holder With 24 Pitch Gear, Order P/N 003-1608

PARTS LIST

STUD MOUNT COBRA/UNIVERSAL TORCH HOLDER

P/N 003-0093

CLAMPING CAPACITY: .75 (19mm) DIA. THRU 1.75 (44mm) DIA. MUST BE USED WITH CLAMP BLOCK P/N 003-0032.

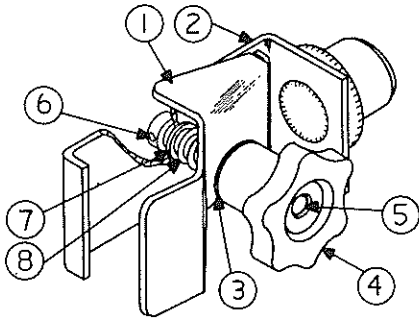

- | | |
|-------------------------------|--|
| 1. Clamp Torch-P/N 435-0031 | 6. Spring Pin 1/8" x 3/4" lg. P/N 421-0180 |
| 2. Bracket Torch-P/N 002-0127 | 7. Flat Wshr Steel-P/N 331-0025 (2) |
| 3. Flat Wshr Steel-P/N 331 | 8. Compression Spring .480 I.D. x .045 Wire x .75 lg.-P/N 419-0024 |
| 4. Knob-P/N 401-0014 | |
| 5. Stud Pivot-P/N 445-0007 | |

STUD MOUNT KING TORCH HOLDER .70 (17.8mm) THRU 1.06 (27mm) DIA.

P/N 003-0620

SUPPLIED WITH TWO SETS OF INSULATORS FOR USE WITH THE STANDARD 5/8" (16mm) DIA. KING COBRA BARREL ASSEMBLIES AND THE OPTIONAL HEAVY DUTY 1" (25.4mm) DIA. KING COBRA BARREL ASSEMBLIES. MUST BE USED WITH CLAMP BLOCK P/N 003-0032.

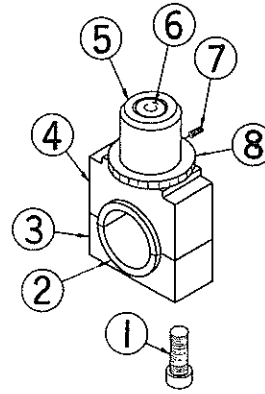

- | | |
|--|--|
| 1. Soc Hd Cap Scr 10-24 x 7/8"-P/N 328-0039 (2) | 4. Torch Holder-P/N 431-0634 |
| 2. Insulator Torch Holder .70 (17.8mm)-.75 (19mm) Dia.-P/N 261-0077 (2) | 5. Adapter Plug-P/N 431-1037 |
| 2. Insulator Torch Holder 1.0 (25.4mm)-1.06 (27mm) Dia.-P/N 261-0076 (2) | 6. Soc Hd Cap Scr 3/8-16 x 5/8"-P/N 328-0109 |
| 3. Clamp Torch Holder-P/N 431-0635 | 7. Scr Cps 6-32 x 3/16"-P/N 321-0027 |
| | 8. Index Ring-P/N 431-0747 |

STUD MOUNT AUTOMATIC TORCH HOLDER 1.43 (36mm) THRU 1.50 (38mm) DIA.

P/N 003-0621

USED TO HOLD 750 AMP M.K. PRODUCTS, INC. TORCH OR ANY AUTOMATIC TORCH 1.43 (36mm) DIA. THRU 1.50 (38mm) DIA. MUST BE USED WITH CLAMP BLOCK P/N 003-0032.

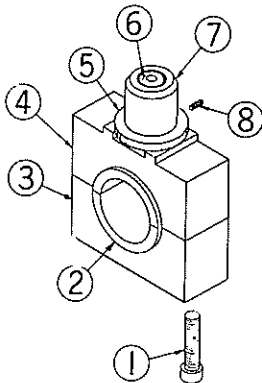

- | | |
|---|--|
| 1. Soc Hd Cap Scr 1/4-20 x 2"-P/N 328-0064 (2) | 5. Index Ring-P/N 431-0747 |
| 2. Insulator Torch Holder 1.43 (36mm)-1.50 (38mm) Dia.-P/N 261-0089 (2) | 6. Soc Hd Cap Scr 3/8-16 x 5/8"-P/N 328-0109 |
| 3. Torch Block Half-P/N 431-1029 | 7. Adaptor Plug-P/N 431-1037 |
| 4. Torch Block Threaded Half P/N 431-1028 | 8. Scr Cps 6-32 x 3/16"-P/N 321-0027 |

STUD MOUNT WIGGLER MOUNTING BRACKET P/N 003-0105

USED TO HOLD M.K. PRODUCTS, INC. WIGGLER TRACTOR ASSEMBLY P/N 001-0329. MUST BE USED WITH CLAMP BLOCK P/N 003-0032.

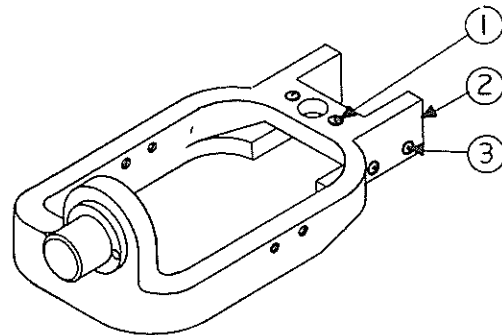

- | | |
|--|--|
| 1. Soc Hd Cap Scr 6-32 x 3/8"-P/N 328-0012 (2) | 3. Soc Hd Cap Scr 6-32 x 5/8"-P/N 328-0014 (4) |
| 2. S/A Yoke-Wiggler-P/N 003-0118 | |

PARTS LIST

QUICK DISCONNECT CLAMP

P/N 003-0058

USED WITH THE FOLLOWING QUICK DISCONNECT HOLDERS:
 QUICK DISCONNECT COBRA/UNIVERSAL TORCH HOLDER P/N 003-0101
 QUICK DISCONNECT KING TORCH HOLDER P/N 003-0622
 QUICK DISCONNECT AUTOMATIC TORCH HOLDER P/N 003-0623

MUST BE USED WITH CLAMP BLOCK P/N 003-0032.

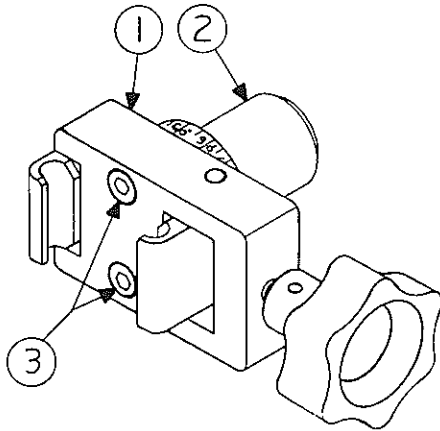

- | | |
|--------------------------------|---------------------------------|
| 1. Clamp Assembly-P/N 001-0146 | 3. Soc Hd Cap Scr 10-32 x 5/8"- |
| 2. Adaptor-P/N 431-0556 | P/N 328-0047 (2) |

QUICK DISCONNECT COBRA/UNIVERSAL TORCH HOLDER

P/N 003-0101

CLAMPING CAPACITY: .75 (19mm) DIA. THRU 1.75 (44mm) DIA. MUST BE USED WITH QUICK DISCONNECT CLAMP P/N 003-0058 AND CLAMP BLOCK P/N 003-0032.

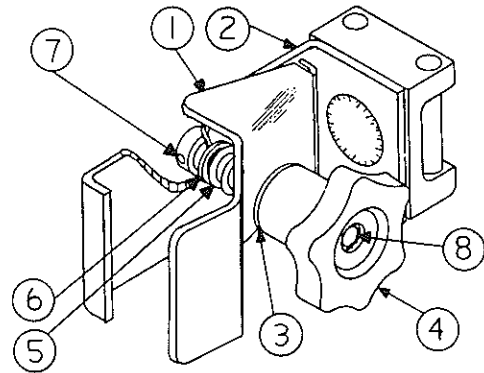

- | | |
|--|--|
| 1. Clamp Torch-P/N 435-0031 | 6. Flat Washer Steel-P/N 331-0025 (2) |
| 2. Bracket-Quick Disconnect-P/N 002-0133 | 7. Spring Pin 1/8" x 3/4" lg.-P/N 421-0180 |
| 3. Flat Washer Steel-P/N 331-0006 | 8. Stud Pivot-P/N 445-0007 |
| 4. Knob-Shaft-P/N 401-0014 | |
| 5. Compression Spring .480 I.D. x .045 Wire x .75 lg.-P/N 419-0024 | |

QUICK DISCONNECT KING TORCH HOLDER

.70 (17.8mm) THRU 1.06 (27mm) DIA.

P/N 003-0622

SUPPLIED WITH TWO SETS OF INSULATORS FOR USE WITH THE STANDARD 5/8" (16mm) DIA. KING COBRA BARREL ASSEMBLIES AND THE OPTIONAL HEAVY DUTY 1" (25.4mm) DIA. KING COBRA BARREL ASSEMBLIES. MUST BE USED WITH QUICK DISCONNECT CLAMP P/N 003-0058 AND CLAMP BLOCK P/N 003-0032.

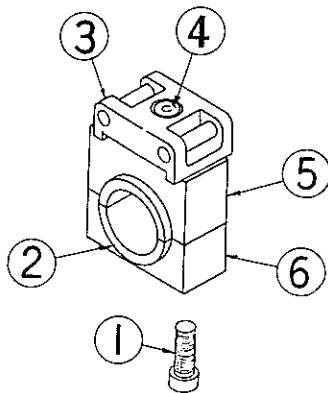

- | | |
|--|--|
| 1. Soc Hd Cap Scr 10-24 x 7/8"-P/N 328-0039 (2) | 3. Adaptor Quick Disconnect-P/N 431-1036 |
| 2. Insulator Torch Holder .70 (17.8mm)-.75 (19mm) Dia.-P/N 261-0077 (2) | 4. Soc Hd Cap Scr 3/8-16 x 3/4"-P/N 328-0110 |
| 2. Insulator Torch Holder 1.0 (25.4mm)-1.06 (27mm) Dia.-P/N 261-0076 (2) | 5. Torch Block Threaded Half-P/N 431-0634 |
| | 6. Torch Block Half-P/N 431-0635 |

QUICK DISCONNECT AUTOMATIC TORCH HOLDER

P/N 003-0623

USED TO HOLD 750 AMP M.K. PRODUCTS, INC. TORCH OR ANY AUTOMATIC TORCH 1.43 (36mm) DIA. THRU 1.50 (38mm) DIA. MUST BE USED WITH QUICK DISCONNECT CLAMP P/N 003-0058 AND CLAMP BLOCK P/N 003-0032.

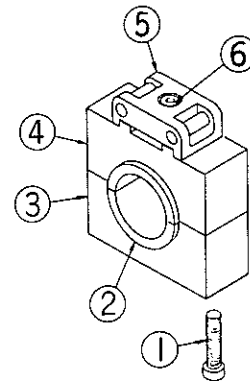

- | | |
|---|--|
| 1. Soc Hd Cap Scr 1/4-20 x 2"-P/N 328-0064 (2) | 4. Torch Block Threaded Half-P/N 431-1028 |
| 2. Insulator Torch Holder 1.43 (36mm)-1.50 (38mm) Dia.-P/N 261-0089 (2) | 5. Adaptor Quick Disconnect-P/N 431-1036 |
| 3. Torch Block Half-P/N 431-1029 | 6. Soc Hd Cap Scr 3/8-16 x 3/4"-P/N 328-0110 |

PARTS LIST

STANDARD TRACK W/GEAR RACK

P/N 001-0384 4'(120cm) Track W/Gear Rack
 P/N 001-0624 6'(180cm) Track W/Gear Rack
 P/N 001-0385 8'(240cm) Track W/Gear Rack
 P/N 001-0386 12'(360cm) Track W/Gear Rack

TO COUPLE TWO OR MORE TRACK SECTIONS, USE ONE TRACK CLAMP KIT P/N 005-0052 PER CONNECTION. TRACK LENGTHS MAY VARY FROM 1/16" TO 3/16" (1.6 To 4.8mm) SHORT OF GIVEN LENGTH.

NOTE: See Safety Regulation Section For Load Capacities.

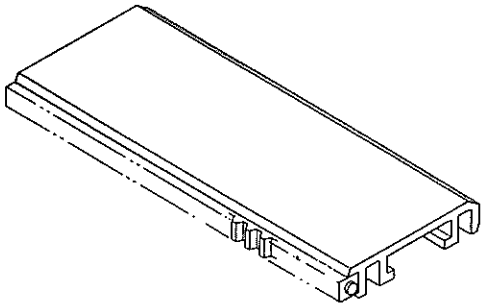

HEAVY DUTY TRACK W/GEAR RACK

P/N 001-0620 4'(120cm) Track W/Gear Rack
 P/N 001-0623 6'(180cm) Track W/Gear Rack
 P/N 001-0621 8'(240cm) Track W/Gear Rack
 P/N 001-0622 12'(360cm) Track W/Gear Rack

TO COUPLE TWO OR MORE TRACK SECTIONS, USE ONE TRACK CLAMP KIT P/N 005-0052 PER CONNECTION. TRACK LENGTHS MAY VARY FROM 1/16" TO 3/16" (1.6 To 4.8mm) SHORT OF GIVEN LENGTH.

NOTE: See Safety Regulation Section For Load Capacities.

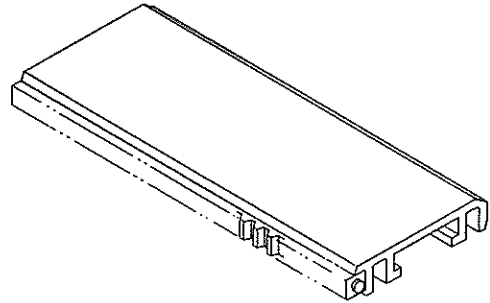

TRACK CLAMP KIT

P/N 005-0052

USED TO CONNECT TWO EXISTING TRACK ASSEMBLIES WITH THE USE OF A QUICK RELEASE CAM SYSTEM. ITEMS 4, 8, 9, & 10 ARE AVAILABLE AS AN ASSEMBLY P/N 003-0057 CAM HANDLE. STANDARD TRACK AND HEAVY DUTY TRACK MAY BE COUPLED TOGETHER.

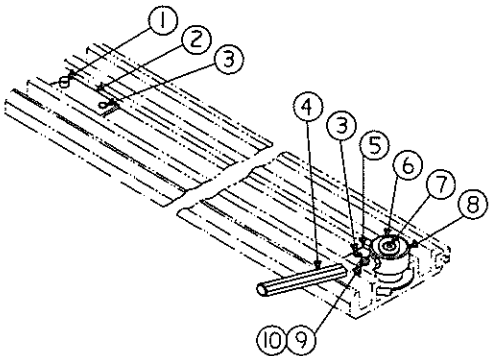

- | | |
|--|--|
| 1. Screw Track Clamp-P/N 431-0597 | 6. Eccentric-Track Clamp-P/N 431-0599 |
| 2. Latch Plate-P/N 431-0612 | 7. Soc Hd Shldr Scr 5/16 x 1 1/4"-P/N 330-0013 |
| 3. Flat Hd Soc Cap Scr 10-24 x 3/8"-P/N 319-0021 (2) | 8. Cam-Track Clamp-P/N 431-0598 |
| 4. Handle-Latch-P/N 415-0021 | 9. Soc Hd Cap Scr 8-32 x 1/4"-P/N 328-0023 |
| 5. Cam Plate-P/N 431-0613 | 10. Lock Nut 8-32-P/N 345-0046 |

STUD MOUNTING BRACKET

P/N 001-0148

FOR STUD OR BOLT MOUNTING APPLICATIONS. MOUNTS DIRECTLY ON STANDARD OR HEAVY DUTY TRACK ASSEMBLIES USING A QUICK RELEASE LOCKING SYSTEM.

NOTE: See Safety Regulation Section For Recommended Mounting Bracket Spacing.

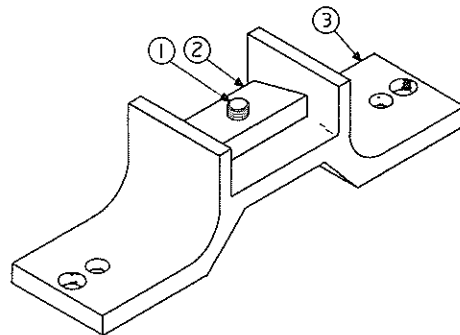

- | | |
|---|---|
| 1. Cap Scr 3/8-16 x 1 3/8"-P/N 329-0214 | Not Shown: |
| 2. Clamp-Track-P/N 431-0190 | 4. 3/8" Internal Lock Washer Steel-P/N 333-0049 |
| 3. Clamp-Machined-P/N 413-0020 | 5. 3/8" Flat Washer Steel-P/N 331-0007 |

PARTS LIST

2" (50.8mm) MAGNETIC MOUNTING BRACKET P/N 003-0601

OPTIONAL MOUNTING BRACKET FOR HORIZONTAL APPLICATIONS ONLY.

NOTE: See Safety Regulation Section For Additional Load Limit Information.

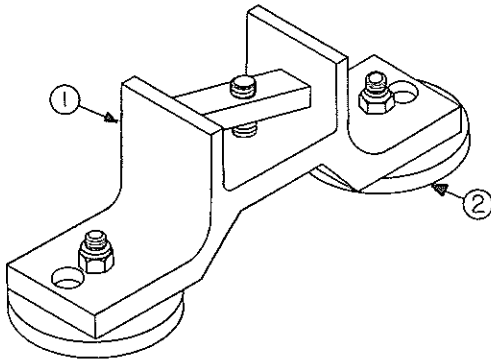

1. Stud Mounting Bracket-P/N 001-0148

2. 2" (50.8mm) Magnet W/Stud Assembly-P/N 003-0609 (2)

3" (76mm) STANDARD MAGNETIC MOUNTING BRACKET P/N 001-0359

STANDARD MOUNTING BRACKET INCLUDED WITH ALL PACK RAT SYSTEMS. THIS BRACKET IS CAPABLE OF SUPPORTING 33 LBS.(15 kg) WHEN IN CONTACT WITH FLAT STEEL AT RIGHT ANGLES TO DIRECTION FORCE. PULL IS TESTED ON A SMOOTH, CLEAN, FLAT, STEEL PLATE 1/2" (12.7mm) THICK AT FULL CONTACT. ALLOWANCES MUST BE MADE FOR SURFACE CONDITIONS OTHER THAN THOSE STATED ABOVE.

NOTE: See Safety Regulation Section For Additional Load Limit Information.

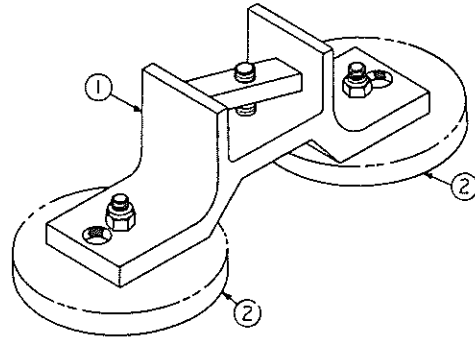

1. Stud Mounting Bracket-P/N 001-0148

2. Standard Magnet W/Stud Assembly-P/N 003-0092 (2)

HEAVY DUTY MAGNETIC MOUNTING BRACKET P/N 001-0358

OPTIONAL HEAVY DUTY MOUNTING BRACKETS ARE RECOMMENDED FOR OUT-OF-POSITION APPLICATIONS. USING TWO HEAVY DUTY MAGNETS, THIS BRACKET IS CAPABLE OF SUPPORTING 100 LBS.(45.7 Kg) WHEN IN CONTACT WITH FLAT STEEL AT RIGHT ANGLES TO DIRECTION FORCE. PULL IS TESTED ON A SMOOTH, CLEAN, FLAT, STEEL PLATE 1/2" (12.7mm) THICK AT FULL CONTACT. ALLOWANCES MUST BE MADE FOR SURFACE CONDITIONS OTHER THAN THOSE STATED ABOVE.

NOTE: See Safety Regulation Section For Additional Load Limit Information.

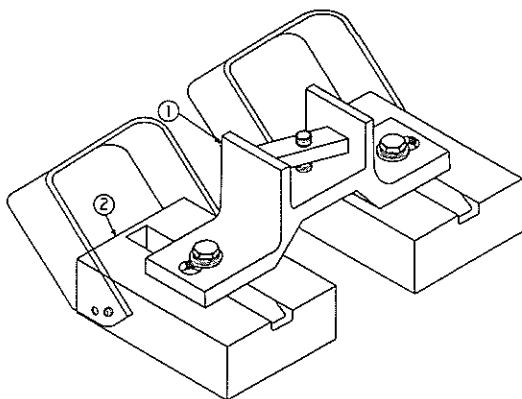

1. Stud Mounting Bracket-P/N 001-0148

2. Heavy Duty Magnetic Assy.-P/N 003-0166 (2)

SUCTION MOUNTING BRACKET P/N 001-0399

OPTIONAL SUCTION MOUNTING BRACKETS ARE FOR USE ON NON-MAGNETIC SURFACES. EACH BRACKET IS EQUIPPED WITH A MANUAL PUMP WHICH DOES NOT REQUIRE AN EXTERNAL VACUUM.

NOTE: See Safety Regulation Section For Additional Load Limit Information.

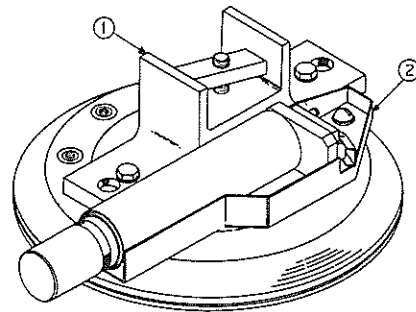

1. Stud Mounting Bracket -P/N 001-0148

2. Suction Pump and Pad Assembly. P/N 001-0414

PARTS LIST

2" (50.8mm) MAGNET WITH STUD ASSEMBLY P/N 003-0609

BOLTS ONTO STUD MOUNTING BRACKET P/N 001-0148.
TWO REQUIRED TO COMPLETE MAGNETIC MOUNTING
BRACKET P/N 003-0601.

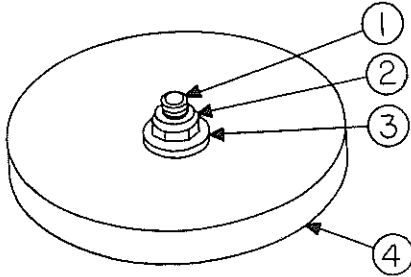

1. Scr Pn Hd 8-32 x 5/8"-P/N 325-0171
2. Hex Nut 8-32-P/N 341-0006

3. Lock Wshr #8-P/N 333-0006
4. Magnet 2" (50.8mm) Dia.-P/N 409-0022

3" (76mm) MAGNET WITH STUD ASSEMBLY P/N 003-0092

BOLTS ONTO STUD MOUNTING BRACKET P/N 001-0148
TWO REQUIRED TO COMPLETE STANDARD MAGNETIC
MOUNTING BRACKET 001-0359.

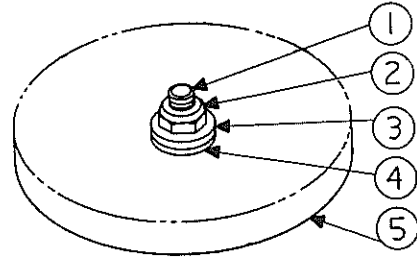

1. Soc Hd Shldr Scr 1/4-10 x 1"-P/N 330-0003
2. Lock Nut 10-24-P/N 345-0012
3. Spherical Washer, Male-P/N 331-0030

4. Spherical Washer, Female-P/N 331-0031
5. Magnet -P/N 409-0021

HEAVY DUTY MAGNET ASSEMBLY P/N 003-0106

BOLTS ONTO STUD MOUNTING BRACKET P/N 001-0148.
TWO REQUIRED TO COMPLETE HEAVY DUTY MAGNETIC
MOUNTING BRACKET P/N 001-0358.

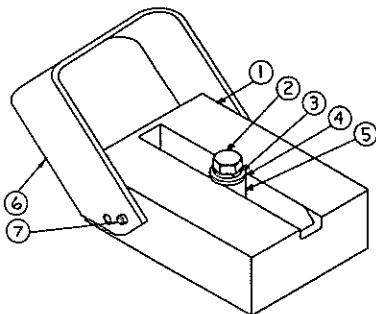

1. Heavy Duty Magnet Assy -P/N 003-0166
2. Hx Hd Cap Scr 1/4-20 x 3/4"-P/N 329-0003
3. Lock Washer Steel-P/N 333-0009
4. Flat Washer Steel-P/N 331-0005

5. Heavy Duty Magnetic Retainer-P/N 431-0742
6. Handle Magnet Quk Ris-P/N 435-0415
7. Dowel Pin 3/16" x 1/2"-P/N 421-0029

SUCTION PUMP AND PAD ASSEMBLY P/N 001-0414

BOLTS ONTO STUD MOUNTING BRACKET P/N 001-0148.
USED TO COMPLETE SUCTION MOUNTING BRACKET P/N
001-0399.

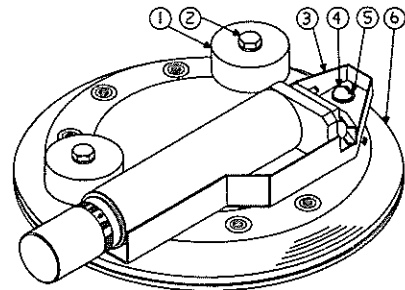

1. Spacer-Suction Mtg.Bracket-P/N 431-0745 (2)
2. Hx Hd Cap Scr 1/4-20 x 1-1/4"-P/N 329-0006 (2)
3. Pump & Bracket-P/N 003-0061

4. Rd Hd Mach Scr 1/4-20 x 5/16"-P/N 323-0280 (2)
5. Spring Lock Washer Steel-P/N 333-0009 (4)
6. Suction Pad-9" (228mm) Dia.-P/N 409-0019

OPTIONAL ACCESSORIES

MULTI-DIRECTION BLOCK P/N 005-0063

THIS BLOCK PROVIDES BOTH HORIZONTAL AND VERTICAL ROTATION OF TORCH HOLDER ASSEMBLIES. MUST BE USED WITH CLAMP BLOCK P/N 003-0032.

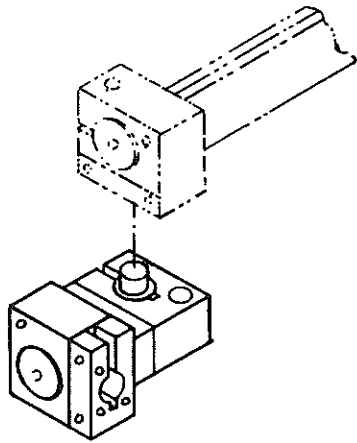

LIMIT SWITCH ASSEMBLY P/N 003-0616

THIS SWITCH AUTOMATICALLY STOPS THE TRAVEL CARRIAGE WHEN ACTIVATED BY THE LIMIT SWITCH STOP P/N 435-0362, OR AT THE END OF A TRACK SECTION. THE SWITCH MAY BE MOUNTED ON EITHER SIDE OF THE TRAVEL CARRIAGE USING EXISTING MOUNTING HOLES.

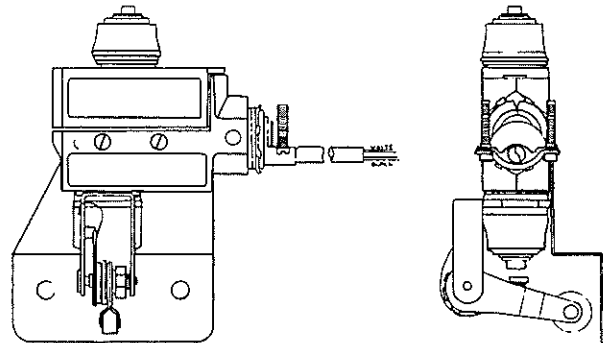

LIMIT SWITCH STOP P/N 435-0362

USED IN CONJUNCTION WITH LIMIT SWITCH ASSEMBLY P/N 003-0616. SLIDES BACK AND FORTH ON TRACK ASSEMBLY AND LOCKS AT DESIRED POSITION.

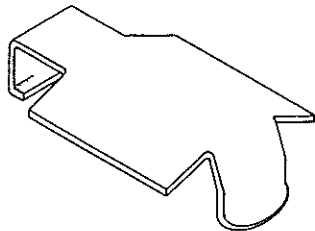

TORCH FLOATER ASSEMBLY P/N 001-0594

THIS ASSEMBLY WILL HOLD ALL TORCH HOLDER ASSEMBLIES AND IS USED TO MAINTAIN A CONSISTENT NOZZLE TIP-TO-WORK DISTANCE. MUST BE USED WITH CLAMP BLOCK P/N 003-0032.

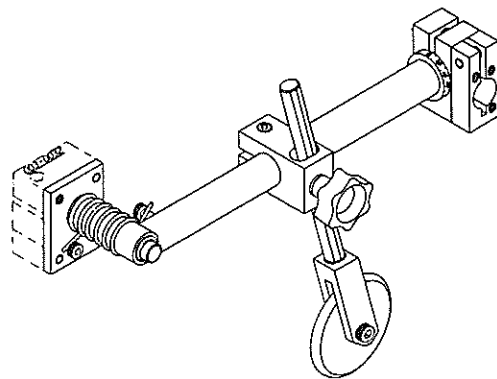

OPTIONAL ACCESSORIES

TRAILER HITCH ASSEMBLY

P/N 431-0686

USED WITH ALL PACK RAT TRAVEL CARRIAGE ASSEMBLIES. ALLOWS AN ADDITIONAL TRACTOR PLATE ASSEMBLY TO BE TOWED BEHIND AN EXISTING TRAVEL CARRIAGE.

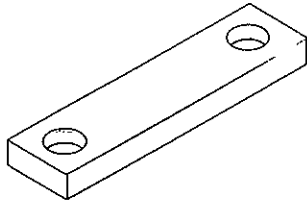

Includes Two Soc Hd Shldr Scr:
3/8"-16 x 1/2"-P/N 330-0034
(Not Shown)

GAS SOLENOID KIT

P/N 003-0230

THIS AUXILIARY CONTROL WORKS IN CONJUNCTION WITH THE STANDARD MANIFOLD BLOCK TO ALLOW SOLENOID OPERATED CONTROL OF THE CUTTING OXYGEN FLOW. A PUSH BUTTON JOG SWITCH IS PROVIDED FOR POSITIONING TRAVEL CARRIAGE. A CUT TOGGLE SWITCH ACTIVATES BOTH TRAVEL AND CUTTING OXYGEN FLOW SIMULTANEOUSLY.

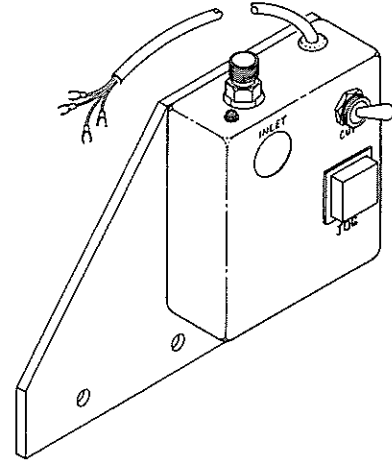

GAS MANIFOLD WITH BALL VALVE

P/N 003-1225

THIS ASSEMBLY ALLOWS CONVENIENT ON/OFF CONTROL OF PREHEAT AND CUTTING OXYGEN USING THREE (3) BALL LEVER VALVES. TWO OF THESE VALVES ARE GANGED TOGETHER ALLOWING SIMULTANEOUS PREHEAT ON/OFF OPERATION.

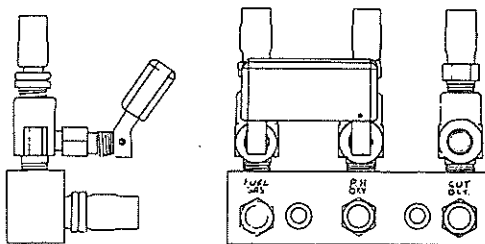

WIRING SCHEMATIC

Dwg. No. 071-0141

CONTROL BOX
PART NUMBERS:
003-1609
003-1612
003-1618

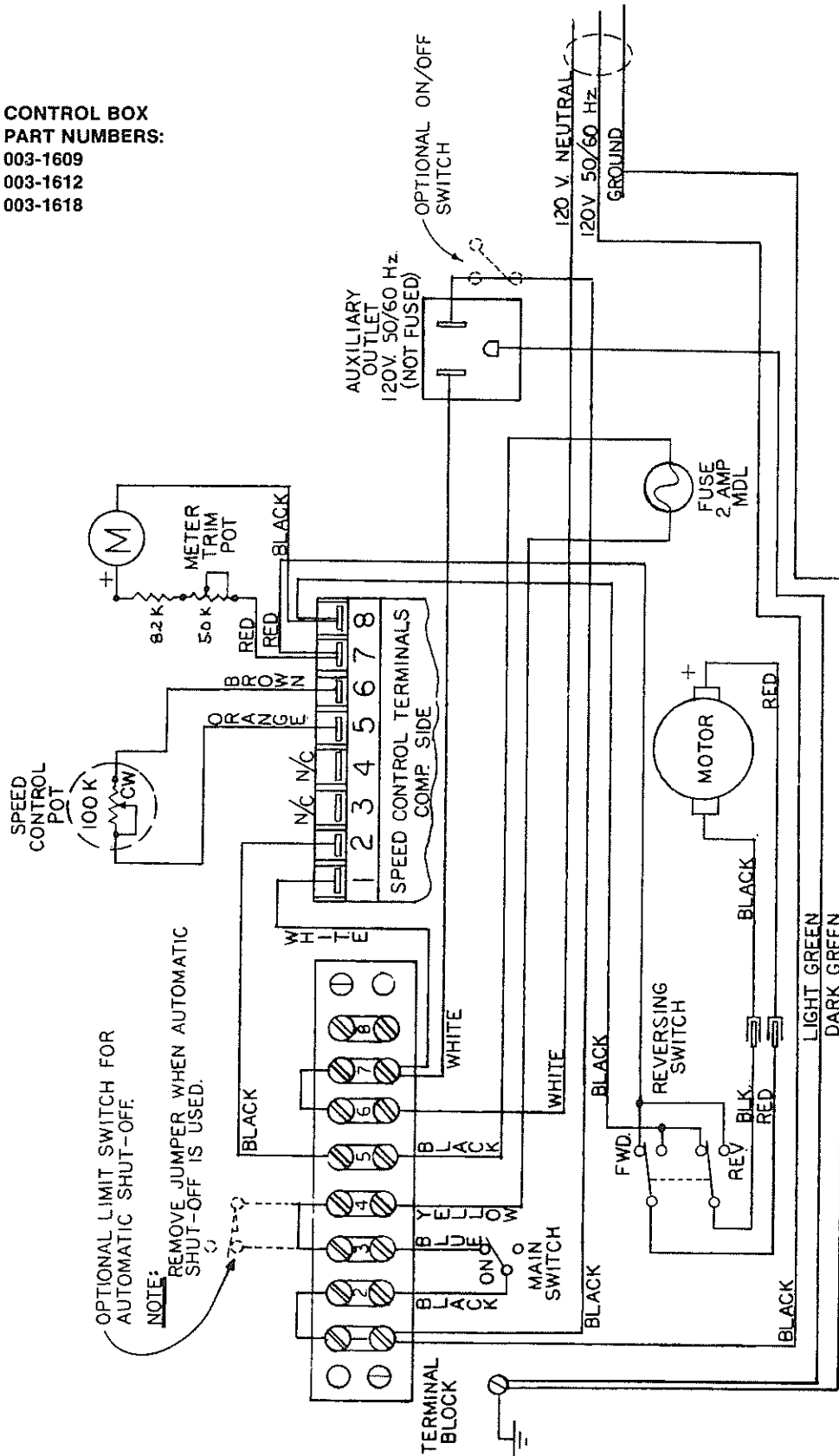

**THE PACK RAT II®
WIGGLER®/COBRAMATIC®
SYSTEM**

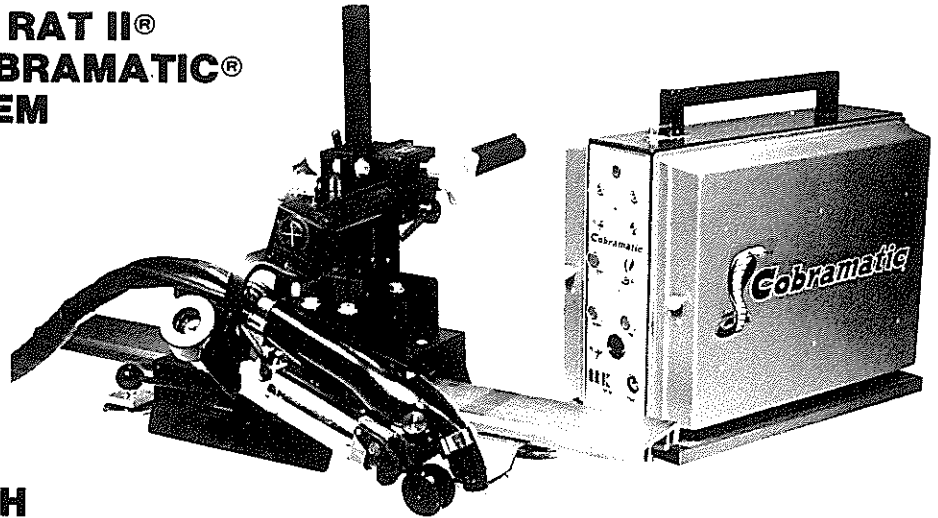

**"T" RACK WITH
KING COBRA® GUN**

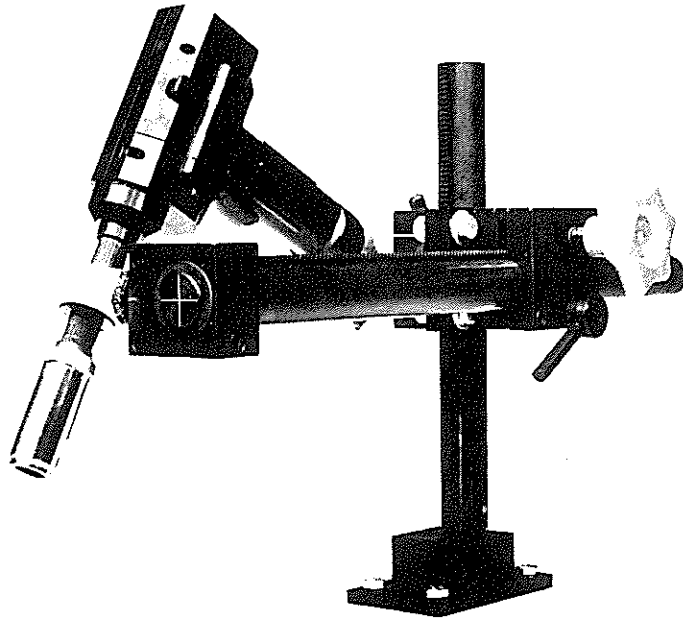

**THE
PACK RAT II® CUTTING
SYSTEM**

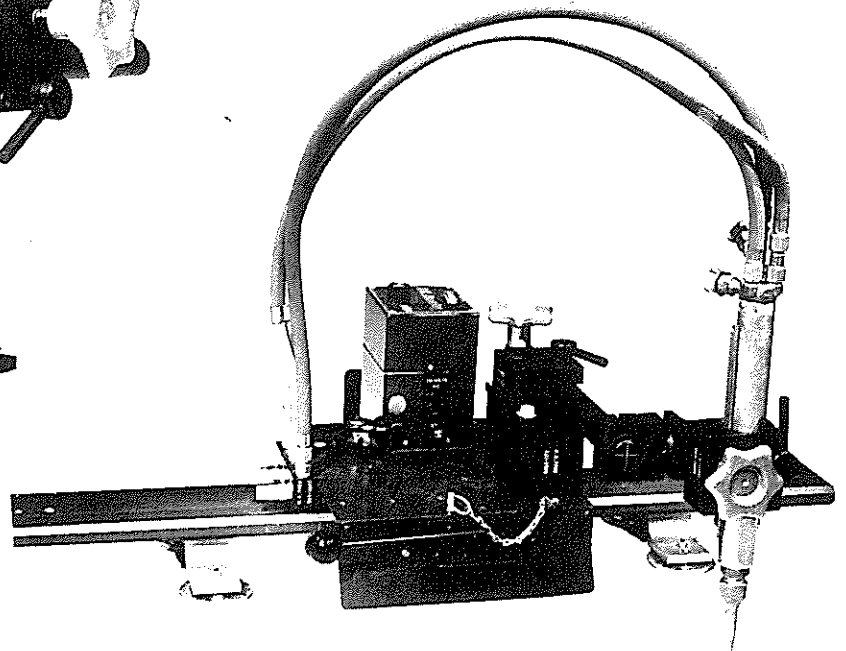

FORM PR/OM -2
NWSA 250
May 1982

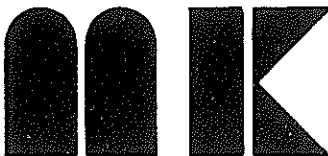

M.K. PRODUCTS, INC.
16882 Armstrong Avenue
Irvine, California 92714
Phone: 714-863-1234
Telex: 69-2369